

Refrigerators, freezers and
wine conditioning units



Welcome to Miele



IMMER BESSER (forever better) – our pledge

When our two great grandfathers were in the process of founding the Miele company, they had to make sure they stood apart from the competition in order to be successful. There are effectively only two ways of doing this: either by being cheaper than the rest or by being better than the rest. It is not really possible to be both at the same time.

They decided to be “better“ than the rest.

Numerous best in class awards and certificates attest to the fact that Miele has continued to renew its commitment to being “immer besser“ throughout the past 115 years. However, the millions of satisfied customers around the world are perhaps the most important endorsement.

At the heart of this success lies a continuity of values and goals which are typically only found in companies which have been family-run for generations, rather than in businesses which are guided by the often short-term interests of the stock market.

It is in this sense that Miele has embodied first-class product quality and German engineering since 1899. Miele also stands in equal measure for respect, fairness and mutual esteem towards sales partners, customers, suppliers, employees and neighbours. Buying a Miele is an environmentally friendly decision. We ensure this by using methods of production that save resources as well by producing products which set new standards in terms of their consumption of electricity, water and detergent – and save you money at the same time.*

As directors and co-proprietors of the fourth generation of our business we promise you that this will not change.



Dr. Markus Miele



Dr. Reinhard Zinkann

* Please visit www.miele-sustainability.com for more information on our efforts and guiding principles

IMMER BESSER

Our brand promise

There are many good reasons for choosing Miele.

Here are just six of them.

Since the company was founded in 1899, Miele has remained true to its ‚Immer Besser‘ brand promise. This means that we will do all that we can to be ‚forever better‘ than our competitors and ‚forever better‘ than we already are. For our customers this means the peace of mind of knowing that choosing Miele is a good decision – and probably the decision of a lifetime!



The Miele brand

In many countries, Miele is the most desired brand in its field. In its German home market, Miele was even voted ‚best brand ever‘ in 2013 across all product branches. And the ownership of products from such a brand reveals much about its users: Miele customers have high expectations for the performance, convenience, design and the environmental friendliness of their domestic appliances. People who buy Miele are quality conscious and have style!



Miele quality

For more than 100 years it has been a proven adage that you can trust Miele and rely on our appliances. We are the only manufacturer in our branch of industry to test products such as our washing machines, tumble dryers, dishwashers and ovens to the equivalent of 20 years of use. Once a Miele, always a Miele: Miele customers around the world remain loyal to Miele and recommend Miele to others. Looking to the future, we promise not to entertain any compromises when it comes to quality and durability!



Miele technology

Miele stands for excellent results combined with the lowest possible energy consumption. This goes for the hygienic and gentle care of your laundry, your flooring and your crockery as well as when conjuring up exquisite culinary delights. The key to this is a wealth of innovative features available only from Miele. This is borne out by numerous first places in leading product tests conducted around the world.



Miele convenience

Whether conventional rotary switch, discreet sensor controls or a high-resolution touch display like the one on your smartphone: operating a Miele is both easy and fun. Add to this a multitude of convenient and reliable automatic programmes and a great love of detail - success is guaranteed - on board both laundry and kitchen appliances. Make life easier for yourself with Miele!



Miele design

Miele believes in clean lines and timeless elegance. Nowhere else will you find such a comparable range of built-in kitchen appliances, with consistency in Design lines and colour options, to suit the most diverse of interior designs and kitchen furniture fronts. Great care is taken to coordinate appliance design across the range. Whatever the style of your kitchen: Miele is the perfect match.



Miele service

Miele customers enjoy preferential treatment: thanks to our fast and efficient after-sales service operation which has been voted best in its branch of industry many times over. Even if you need personalised instructions on appliance use or professional cleaning of your machines, Miele will gladly make a home visit. We will always be there for you. That's a promise!

Wide variety of models for modern lifestyles

Miele refrigerators, freezers and wine conditioning units



With its refrigeration appliances, Miele offers an extremely wide variety of models equipped with state-of-the-art technology and unique convenience. Every appliance was designed specifically for its purpose and to meet the highest of demands in terms of quality and durable functionality. The exceptional Miele design is easily recognisable – high-quality materials and clear lines throughout the entire appliance. That is Miele.



Contents

Introduction

The range	8
PerfectFresh	10
User interfaces	16
Efficiency and sustainability	18
Wine conditioning units	20
Side-by-Side - overview	22

Product benefits

Miele refrigerators and freezers - the highlights	24
Further product benefits	26

Products

Product information	28
Accessories	38
Installation drawings	40
Glossary	42



Wide variety of models for modern lifestyles

Miele refrigerators, freezers and wine conditioning units

Miele appliances inspire with their special highlights by ensuring that all types of food is kept fresh, frozen or stored under ideal conditions. From built-in to freestanding appliances – Miele appliances contribute to a healthy and modern life.





Refrigerators

Miele refrigerators are designed to keep your groceries fresh in an efficient and well organised way. Intelligent PerfectFresh compartments guarantee that food is kept expertly fresh. Choose "Your Miele" from a wide range of appliances including 178 cm high integrated appliances and freestanding appliances from 182 cm to 185 cm high.



Fridge-freezers

These appliances offer plenty of storage space for fresh food and frozen food, each section with its own door. Miele fridge-freezer combinations combine convenient, gentle storage of fresh food as well as frozen food in one appliance.



Freezers

Miele freezers are powerful and efficient, and exemplary in terms of organisation and functionality. They can be set up as stand-alone appliances or combined with a matching Miele refrigerator. The exterior with its puristic, timeless design is simply striking and its inner values convince, for example, with a freezing temperature that can be regulated down to -26°C .



Wine conditioning units

Miele wine conditioning units provide the optimum storage conditions for your wine collection. With individually controlled temperature zones for different types of wine, your reds and whites are guaranteed professional treatment. Not only does a Miele wine conditioning unit provide the best storage conditions for your wine, it will also look the part in your home.

PerfectFresh

Pure enjoyment and natural taste!





Purchased when fresh – but how do you retain the freshness?

Fresh food is the basis for wholesome, healthy living. Fruit and vegetables should be consumed when they are as crisp and as fresh as when they are purchased. But who has the time nowadays to buy ingredients fresh every day?

Apart from the quality of the food at the point of purchase, the right storage conditions are also important. The storage conditions determine how fresh, tasty and healthy food still is when preparing it for consumption. This is easily achieved with PerfectFresh.

Clever cooling – healthy eating

PerfectFresh is the synonym for innovative food storage at Miele: a special cooling zone in Miele refrigerators which offers ideal storage conditions for a variety of food. Thanks to the PerfectFresh zone, many types of fruit and vegetables, meat, fish and milk products remain fresh considerably longer than in conventional refrigerators. At a temperature of between 0°C and 3°C, as well as ideal humidity levels, even sensitive food can be stored in ideal conditions and retain its freshness.

Food is valuable

In German households, 20% of all purchased food ends up being thrown away. One of the reasons is because they are not stored in ideal conditions and therefore spoil after a short while. Half of this food is fruit and vegetables. On average, every German disposes of over \$450 worth of food every year.

You can improve on that – with PerfectFresh

Important vitamins and minerals are retained longer. Freshness you can see and taste!

Highest level of expertise for fresh food

Dry and humidity-controlled compartment

Dry compartment:

In the PerfectFresh dry compartment, meat, fish and almost all dairy products are stored in ideal storage conditions: the temperature is maintained between 0°C and 3°C. When stored in the dry compartment, food is kept fresher for longer.

Humidity controlled compartment:

The PerfectFresh humidity-controlled compartment has been designed specifically for storing fresh fruit and vegetables which require high humidity levels for perfect storage conditions. A storage temperature between 0°C and 3°C, as well as a humidity level of up to 90%*, ensure that your food remains fresh considerably longer.



Food stays fresh for longer

Foodstuff such as meat, fish and dairy products are stored under ideal conditions in the dry compartment. The low temperature between 0°C and 3°C ensures that your food remains fresh and retains its high quality for a long time. This results in less frequent trips to the shop and less waste, saving time and money for other nice things.

Tip: store food in its packaging or covered in the dry compartment, allowing humidity to remain inside the food and preventing the transfer of flavours and odours.

Use all your senses to ensure that the food is of high quality – independently from the best before date.

Food (examples)	Freshness retained longer than in refrigerator
Butter, yeast, sliced meat	Up to 1 week
Cream, butter, milk	Up to 2 weeks
Yoghurt, soft cheese	Up to 3 weeks



Food remains fresh for longer than in a conventional refrigerator

The humidity-controlled compartment is perfect for storing fruit and vegetables. Stored at low temperatures and high humidity levels, your food remains fresh for longer.

Filling the drawer with fresh fruit and vegetables creates humidity which is maintained thanks to a special Miele design. This results in, for example, apples stored in the humidity-controlled drawer staying fresh for longer than when stored in a conventional refrigerator. Fresh fruit and vegetables always available from your refrigerator – crisp and tasty as if fresh from the market. Stored inside the humidity-controlled compartment, vitamins, texture and taste are retained longer.

Tip: place fruit and vegetables in their packaging in the drawer to allow humidity to develop. To ensure that a sufficient humidity level develops, the compartment should always be well stocked.

If required, this compartment can be turned into a dry compartment by adjusting the humidity level using the slide control.

Food (examples)	Freshness retained longer than in refrigerator
Lettuce, mushrooms, onions, strawberries, blueberries, nectarines	Up to 1 week
Asparagus, kale, plums, rhubarb, peaches, cherries	Up to 2 weeks
Pears, apples, carrots	Up to 4 months



PerfectFresh Pro

Professional food storage with Miele





Through intensive research, Miele succeeded in developing the PerfectFresh freshness principle even further. The result: PerfectFresh Pro.

PerfectFresh Pro keeps fruit and vegetables fresh for even longer and therefore meets the highest of demands. This is achieved with an innovative compartment cover with Miele's special perforations. It maintains the climate inside the humidity-controlled drawer precisely.

Food* (examples)	PerfectFresh (freshness retained longer compared with a refrigerator)	PerfectFresh Pro (freshness retained longer compared with a refrigerator)
Lettuce, mushrooms, onions, strawberries, blueberries, nectarines	Up to 1 week	Up to 2 weeks
Asparagus, kale, plums, rhubarb, peaches, cherries	Up to 2 weeks	Up to 3 weeks

Professional food storage with PerfectFresh Pro. An innovation from Miele – the freshness expert.

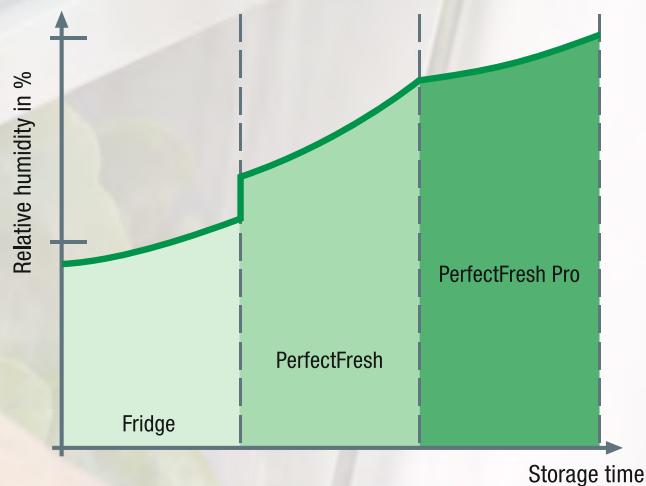

* Storage in full PerfectFresh / PerfectFresh Pro compartment and market-fresh produce

User interfaces from Miele

Never before was the operation of refrigerators, freezers and wine conditioning units easier



User interfaces from Miele are extremely user-friendly. Every refrigeration appliance features a modern user interface which combines functions and design perfectly.



Miele touch controls

Miele touch controls for built-in appliances are design oriented. All key features look the same, achieving perfect design harmony in line with other Miele built-in appliances. Main functions can be quickly and directly accessed via the touch controls. All other functions are selected via the display.



ComfortControl

ComfortControl allows the convenient setting of temperature, automatic SuperCool or buzzer via light-touch switches. LEDs indicate the temperature.

Efficiency and sustainability

Saving energy the environmentally friendly way with Miele refrigerators and freezers





Miele refrigerators and freezers achieve top ratings. With its current refrigeration products, Miele demonstrates that high performance and energy-saving can be achieved simultaneously. Miele invests a great deal in the continuous development of modern technologies such as the optimisation of the refrigeration circuit and insulation - with success, as Miele refrigerators consume at least 40% less energy than comparable models. All Miele refrigeration appliances enjoy being top of their class and set standards in terms of environmental friendliness. Even Miele's flagship appliances are extremely economical. With an appliance which is in use 24 hours a day, every day over many years, this benefit goes straight to your pocket and is gentle on the environment. Miele refrigerators and freezers are always an excellent choice – for your home and the environment.



Sustainable innovations
www.mielesustainableinnovations.com.au

Miele wine conditioning units

Wine conditioning units with style and many highlights

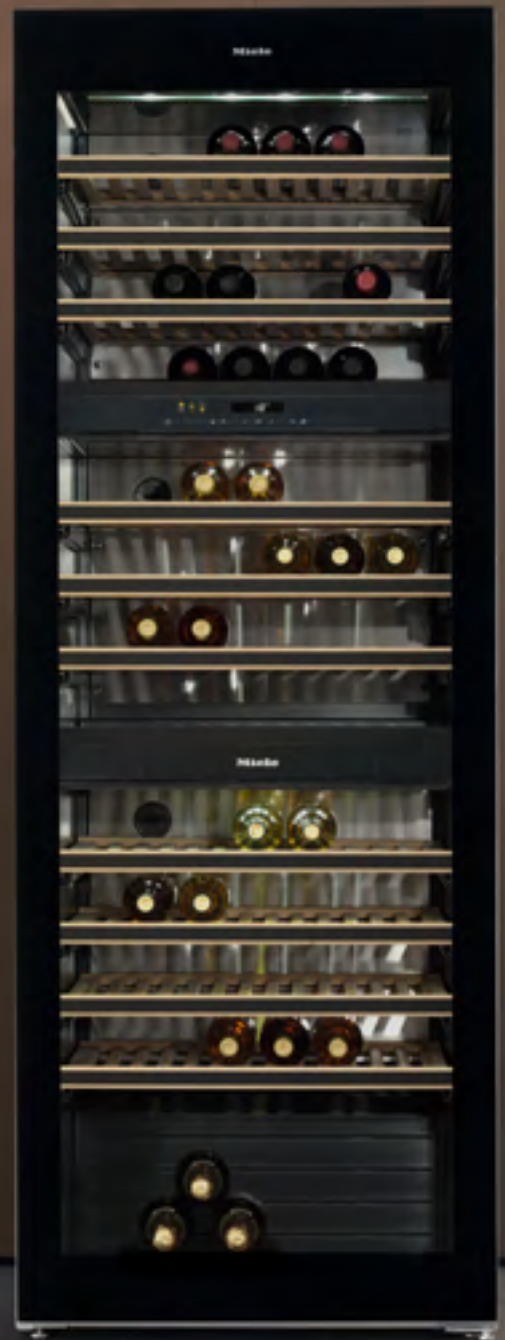



For real wine connoisseurs, enjoyment of wine starts with the selection of wine and the correct storage in their own home. These factors influence how long wine can be stored without losing its excellent taste. The correct storage conditions of wine have a direct effect on its shelf life. A wine conditioning unit from Miele offers the ideal conditions for storage of the finest wines. To suit different types of wine, precise and individual selection of several temperature zones in your conditioning unit is possible. This allows you to store various wines under ideal conditions. Particularly when storing wine over long periods of time, storage facilities must meet specific demands in terms of ambient temperature. Wine conditioning units from Miele are an excellent solution and maintain a steady temperature. The features of these units are as individual as the wine stored in them. As built-in versions, they integrate perfectly into your kitchen design and as flexible freestanding appliances they are real eye-catchers.

Side-by-Side

Miele's wide range of refrigerators, freezers and wine conditioners

Miele refrigeration appliances are not just excellent in terms of their scope, quality and premium design, they are also known for being extremely flexible. For instance you can combine two refrigerators or built-under wine conditioners next to each other, or have a classical combination of side-by-side refrigerator and freezer.

The following built-in appliances are designed for a 60 cm wide tall unit and installed next to one another. They do not have to be installed in any particular order so you can decide how you want to arrange them.

Fridge/Freezer	KFNS 37432 iD KFNS 37452 iDE KFNS 37682 iD KFNS 37692 iDE
Refrigerator	KS 37422 iD KS 37472 iD
Freezer	FNS 37402 i

The following freestanding appliances are 60 cm wide and can be set up next to one another:

Appliance on the left	Appliance on the right
FN 12827 S	K 12820 SD
FN 12827 S edt/cs	K 12820 SD edt/cs
FN 14827 S ed/cs-1	K 14820 SD ed/cs
FN 14827 S ed/cs-1	K 14827 SD ed/cs
KFN 14827 SDE ed/cs-2	K 14820 SD ed/cs



Miele highlights for perfect results and more convenience

The product highlights* of Miele refrigerators, freezers and wine conditioning units



PerfectFresh

Apart from the quality of the food at the point of purchase, the right storage conditions are also important. The storage conditions determine how fresh, tasty and healthy food still is when preparing it for consumption. This is easily achieved with PerfectFresh – perfect storage conditions for fresh produce to retain vitamins, nutrients and flavours!



Exclusive to Miele **PerfectFresh Pro**
For even more freshness: innovative Miele technology keeps fruit and vegetables fresh even longer.



Exclusive to Miele **FlexiLight**
Perfect glare-free lighting: depending on the food stored, the interior lighting can be positioned at all rack levels.



NoFrost
Convenient: manual defrosting no longer necessary. Cooled air is circulated and prevents the formation of ice on food.



DynaCool
Uniform distribution of temperature: a ventilator ensures excellent circulation and distribution of cold air.



Exclusive to Miele **ComfortClean**
Fast cleaning: the high-quality door racks are dishwasher-proof.

* Features will vary depending on model

Further convincing talents

The product benefits* of Miele refrigerators, freezers and wine conditioning units



Exclusive to Miele **VarioBord**
From the fridge straight onto the table: the versatile VarioBord shelves are very easy to take out of their holders and to insert again*.



Exclusive to Miele **EasyOpen lever handle**
Easy to open: the elegant handle allows you to open the door effortlessly.



Exclusive to Miele **Active AirClean filters**
Unspoiled aroma retained: the combination of active charcoal filter and chitosan (a natural product) effectively prevents odours*.



SoftClose
Closes quietly and reliably: the gently self-closing door prevents items from falling out*.



SelfClose
Convenient access: drawers can be pulled out to their full depth and closed again with a gentle touch*.



LED lighting
Maintenance free and economical: efficient and durable LEDs ensure perfect illumination of the interior*.



IceMaker
Produced quickly and stored: Miele's IceMaker has separate controls and can produce approximately 100 ice cubes a day*.



CleanSteel
No fingerprints on stainless steel: the surface is protected and no special cleaning agents are required.



VarioRoom
Adaptable to space requirements: storage space can be re-arranged if more room is required to freeze bulky items.



SuperCool/SuperFreeze

Fast cooling and freezing: ideal for large quantities of food, extra cold drinks or gentle freezing.



FlexiFrame with NoteBoard

Only a single-handed motion is required: individual slats can be repositioned and adjusted to suit the bottle shape. The NoteBoard can be used for individual labelling.



Temperature zones

Separate temperature controls: up to three different types of wine requiring different temperatures can be stored at the same time*.

*Features will vary depending on model

Freestanding Refrigerators



Model	K 12820 SD	K 12820 SD edt/cs	K 14820 SD ed/cs
Appliance category			
Refrigerator/Freezer/Fridge Freezer	●/-/-	●/-/-	●/-/-
Type of appliance			
Freestanding/Integrated	●/-	●/-	●/-
Door hinging/Convertible	Right/●	Right/●	Right/●
Side-by-side compatible/Side-by-side location	●/Right	●/Right	●/Right
Design			
Colour/front	White/White	Stainless steel/CleanSteel	CleanSteel/CleanSteel
Lighting in refrigerator/PerfectFresh/Freezer section	●/-/-	●/-/-	●/-/-
Type of lighting	LED	LED	LED
Capacity			
Total gross volume	405	405	405
Refrigerator volume	405	405	405
PerfectFresh volume	-	-	-
Freezer volume	-	-	-
Freezing capacity (kg/24 h)	-	-	-
Convenience features			
PerfectFresh	-	-	-
PerfectFresh Pro	-	-	-
ComfortClean	-	-	●
DynaCool	●	●	●
SuperCool	●	●	●
SuperFreeze	-	-	-
NoFrost	-	-	-
VarioRoom	-	-	-
Active AirClean filter	-	-	●
SoftClose door damper	-	-	●
SelfClose	-	-	-
IceMaker/Plumbed in/MyIce water tank	-	-	-
EasyOpen lever handle	●	●	●
Refrigerator zone			
No. of shelves/Height adjustable/Sectionable/Illuminated	6/5/1/-	6/5/1/-	6/5/1/-
Chrome plated metal bottle rack	●	●	●
No. of removable vegetable drawers	2	2	2
Storage compartment for butter and cheese	●	●	●
VarioBord	-	-	-
No. of door racks/Door racks for bottles/Half door racks	5/2/-	5/2/-	5/2/-
PerfectFresh zone			
No. of PerfectFresh drawers	-	-	-
Freezer zone			
No. of freezer drawers	-	-	-
Controls			
Electronic temperature display and control	ComfortControl	ComfortControl	TouchControl
Efficiency and sustainability			
Energy efficiency rating	2.5	2.5	2.5
Energy consumption per year	279	279	279
Safety			
Control lock/Power cut indication for the freezer section	●/-	●/-	●/-
Acoustic door alarm/Acoustic temperature alarm	●/●	●/●	●/●
Optical door alarm/Optical temperature alarm	-/●	-/●	-/●
Technical data			
Dimensions in cm (W x H x D) (Recess dimensions for integrated units)	60 x 185 x 63	60 x 185 x 63	60 x 185 x 63
Sound power in dB(A)	37	37	37
Storage time in event of a fault	-	-	-
Accessories supplied			
Cool pack/ice tray	-	-	-





Model	K 14827 SD ed/cs
Appliance category	
Refrigerator/Freezer/Fridge Freezer	●/-/-
Type of appliance	
Freestanding/Integrated	●/-
Door hinging/Convertible	Right/●
Side-by-side compatible/Side-by-side location	●/Right
Design	
Colour/front	CleanSteel/CleanSteel
Lighting in refrigerator/PerfectFresh/Freezer section	●/-/-
Type of lighting	LED
Capacity	
Total gross volume	403
Refrigerator volume	277
PerfectFresh volume	126
Freezer volume	-
Freezing capacity (kg/24 h)	-
Convenience features	
PerfectFresh	●
PerfectFresh Pro	-
ComfortClean	●
DynaCool	●
SuperCool	●
SuperFreeze	-
NoFrost	-
VarioRoom	-
Active AirClean filter	●
SoftClose door damper	●
SelfClose	-
IceMaker/Plumbed in/MyIce water tank	-
EasyOpen lever handle	●
Refrigerator zone	
No. of shelves/Height adjustable/Sectionable/Illuminated	6/5/1/-
Chrome plated metal bottle rack	●
No. of removable vegetable drawers	-
Storage compartment for butter and cheese	●
VarioBord	-
No. of door racks/Door racks for bottles/Half door racks	4/2/-
PerfectFresh zone	
No. of PerfectFresh drawers	3
Freezer zone	
No. of freezer drawers	-
Controls	
Electronic temperature display and control	TouchControl
Efficiency and sustainability	
Energy efficiency rating	3
Energy consumption per year	252
Safety	
Control lock/Power cut indication for the freezer section	●/-
Acoustic door alarm/Acoustic temperature alarm	●/●
Optical door alarm/Optical temperature alarm	-/●
Technical data	
Dimensions in cm (W x H x D) (Recess dimensions for integrated units)	60 x 185 x 63
Sound power in dB(A)	40
Storage time in event of a fault	-
Accessories supplied	
Cool pack/ice tray	-



Freestanding Freezers



Model	FN 12827 S	FN 12827 S edt/cs	FN 14827 S ed/cs
Appliance category			
Refrigerator/Freezer/Fridge Freezer	-/●/-	-/●/-	-/●/-
Type of appliance			
Freestanding/Integrated	●/-	●/-	●/-
Door hinging/Convertible	Left/●	Left/●	Left/●
Side-by-side compatible/Side-by-side location	●/Left	●/Left	●/Left
Design			
Colour/front	White/White	Stainless steel/CleanSteel	CleanSteel/CleanSteel
Lighting in refrigerator/PerfectFresh/Freezer section	-/-/-	-/-/-	-/-/●
Type of lighting	-	-	LED
Capacity			
Total gross volume	304	304	304
Refrigerator volume	-	-	-
PerfectFresh volume	-	-	-
Freezer volume	304	304	304
Freezing capacity (kg/24 h)	20	20	20
Convenience features			
PerfectFresh	-	-	-
PerfectFresh Pro	-	-	-
ComfortClean	-	-	-
DynaCool	-	-	-
SuperCool	-	-	-
SuperFreeze	●	●	●
NoFrost	●	●	●
VarioRoom	●	●	●
Active AirClean filter	-	-	-
SoftClose door damper	-	-	●
SelfClose	-	-	-
IceMaker/Plumbed in/MyIce water tank	-/-/-	-/-/-	-/-/-
EasyOpen lever handle	●	●	●
Refrigerator zone			
No. of shelves/Height adjustable/Sectionable/Illuminated	-/-/-/-	-/-/-/-	-/-/-/-
Chrome plated metal bottle rack	-	-	-
No. of removable vegetable drawers	-	-	-
Storage compartment for butter and cheese	-	-	-
VarioBord	-	-	-
No. of door racks/Door racks for bottles/Half door racks	-/-/-	-/-/-	-/-/-
PerfectFresh zone			
No. of PerfectFresh drawers	-	-	-
Freezer zone			
No. of freezer drawers	8	8	8
Controls			
Electronic temperature display and control	ComfortControl	ComfortControl	TouchControl
Efficiency and sustainability			
Energy efficiency rating	3.5	3.5	3.5
Energy consumption per year	310	310	358
Safety			
Control lock/Power cut indication for the freezer section	-/-	-/-	●/●
Acoustic door alarm/Acoustic temperature alarm	●/●	●/●	●/●
Optical door alarm/Optical temperature alarm	-/●	-/●	-/●
Technical data			
Dimensions in cm (W x H x D) (Recess dimensions for integrated units)	60 x 185 x 63	60 x 185 x 63	60 x 185 x 63
Sound power in dB(A)	40	40	40
Storage time in event of a fault	43	43	43
Accessories supplied			
Cool pack/ice tray	-/●	-/●	●/●



Freestanding Fridge Freezers



Model	KFN 12823 SD-1	KFN 12823 SD edt/cs-1	KFN 14842 SD ed/cs
Appliance category			
Refrigerator/Freezer/Fridge Freezer	-/-●	-/-●	-/-●
Type of appliance			
Freestanding/Integrated	●/-	●/-	●/-
Door hinging/Convertible	Right/●	Right/●	Right/●
Side-by-side compatible/Side-by-side location	-/-	-/-	-/-
Design			
Colour/front	White/White	Stainless steel/CleanSteel	CleanSteel/CleanSteel
Lighting in refrigerator/PerfectFresh/Freezer section	●/-/-	●/-/-	●/-/-
Type of lighting	LED	LED	LED
Capacity			
Total gross volume	339	339	458
Refrigerator volume	231	231	358
PerfectFresh volume	-	-	-
Freezer volume	108	108	100
Freezing capacity (kg/24 h)	14	14	7
Convenience features			
PerfectFresh	-	-	-
PerfectFresh Pro	-	-	-
ComfortClean	-	-	●
DynaCool	●	●	●
SuperCool	-	-	●
SuperFreeze	●	●	●
NoFrost	●	●	●
VarioRoom	●	●	●
Active AirClean filter	-	-	●
SoftClose door damper	-	-	●
SelfClose	-	-	-
IceMaker/Plumbed in/MyIce water tank	-	-	-
EasyOpen lever handle	●	●	●
Refrigerator zone			
No. of shelves/Height adjustable/Sectionable/Illuminated	4/3/1-	4/3/1-	5/4/1-
Chrome plated metal bottle rack	●	●	●
No. of removable vegetable drawers	2	2	2
Storage compartment for butter and cheese	●	●	●
VarioBord	-	-	-
No. of door racks/Door racks for bottles/Half door racks	4/2/-	4/2/-	5/4/-
PerfectFresh zone			
No. of PerfectFresh drawers	-	-	-
Freezer zone			
No. of freezer drawers	3	3	2
Controls			
Electronic temperature display and control	ComfortControl	ComfortControl	TouchControl
Efficiency and sustainability			
Energy efficiency rating	2.5	2.5	3.5
Energy consumption per year	414	414	352
Safety			
Control lock/Power cut indication for the freezer section	-/●	-/●	●/●
Acoustic door alarm/Acoustic temperature alarm	●/●	●/●	●/●
Optical door alarm/Optical temperature alarm	-/●	-/●	-/●
Technical data			
Dimensions in cm (W x H x D) (Recess dimensions for integrated units)	60 x 182 x 63	60 x 182 x 63	75 x 186 x 63
Sound power in dB(A)	40	40	43
Storage time in event of a fault	30	30	21
Accessories supplied			
Cool pack/ice tray	-/●	-/●	●/●



Freestanding Fridge Freezers



Model	KFN 14827 SDE ed/cs
Appliance category	Refrigerator/Freezer/Fridge Freezer
Type of appliance	Freestanding/Integrated
Door hinging/Convertible	Left/●
Side-by-side compatible/Side-by-side location	●/Left
Design	Colour/front
	CleanSteel/CleanSteel
Lighting in refrigerator/PerfectFresh/Freezer section	●/-/-
Type of lighting	LED
Capacity	Total gross volume
	321
Refrigerator volume	171
PerfectFresh volume	Part of 171
Freezer volume	150
Freezing capacity (kg/24 h)	14
Convenience features	PerfectFresh
	●
PerfectFresh Pro	-
ComfortClean	●
DynaCool	●
SuperCool	●
SuperFreeze	●
NoFrost	●
VarioRoom	●
Active AirClean filter	●
SoftClose door damper	●
SelfClose	-
IceMaker/Plumbed in/MyIce water tank	●/●/-
EasyOpen lever handle	●
Refrigerator zone	No. of shelves/Height adjustable/Sectionable/Illuminated
	2/1/-/-
Chrome plated metal bottle rack	●
No. of removable vegetable drawers	-
Storage compartment for butter and cheese	-
VarioBord	-
No. of door racks/Door racks for bottles/Half door racks	-/-/-
PerfectFresh zone	No. of PerfectFresh drawers
	2
Freezer zone	No. of freezer drawers
	3+2
Controls	Electronic temperature display and control
	TouchControl
Efficiency and sustainability	Energy efficiency rating
	3
Energy consumption per year/in 24 h in kWh	358
Safety	Control lock/Power cut indication for the freezer section
	●/●
Acoustic door alarm/Acoustic temperature alarm	●/●
Optical door alarm/Optical temperature alarm	-/●
Technical data	Dimensions in cm (W x H x D) (Recess dimensions for integrated units)
	60 x 185 x 63
Sound power in dB(A)	42
Storage time in event of a fault	31
Accessories supplied	Cool pack/ice tray
	●/-



Built-in Refrigerators

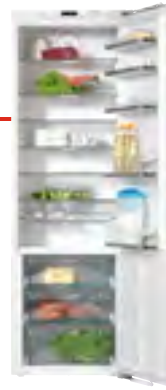
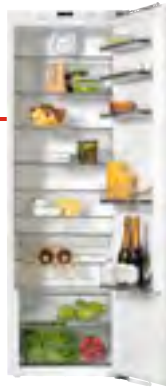

Model	KS 37422 iD	KS 37472 iD
Appliance category		
Refrigerator/Freezer/Fridge Freezer	●/-/-	●/-/-
Type of appliance		
Freestanding/Integrated	-/●	-/●
Door hinging/Convertible	Right/●	Right/●
Side-by-side compatible/Side-by-side location	●/Freely combinable	●/Freely combinable
Design		
Colour/front	-/-	-/-
Lighting in refrigerator/PerfectFresh/Freezer section	●/-/-	●/-/-
Type of lighting	FlexiLight	FlexiLight
Capacity		
Total gross volume	348	344
Refrigerator volume	348	245
PerfectFresh volume	-	99
Freezer volume	-	-
Freezing capacity (kg/24 h)	-	-
Convenience features		
PerfectFresh	-	●
PerfectFresh Pro	-	-
ComfortClean	●	●
DynaCool	●	●
SuperCool	●	●
SuperFreeze	-	-
NoFrost	-	-
VarioRoom	-	-
Active AirClean filter	-	-
SoftClose door damper	●	●
SelfClose	-	●
IceMaker/Plumbed in/MyIce water tank	-	-
EasyOpen lever handle	-	-
Refrigerator zone		
No. of shelves/Height adjustable/Sectionable/Illuminated	7/7/-/4	6/6/-/4
Chrome plated metal bottle rack	●	●
No. of removable vegetable drawers	2	-
Storage compartment for butter and cheese	-	-
VarioBord	●	●
No. of door racks/Door racks for bottles/Half door racks	5/2/-	5/2/-
PerfectFresh zone		
No. of PerfectFresh drawers	-	3
Freezer zone		
No. of freezer drawers	-	-
Controls		
Electronic temperature display and control	TouchControl	TouchControl
Efficiency and sustainability		
Energy efficiency rating	3	1.5
Energy consumption per year/in 24 h in kWh	238	328
Safety		
Control lock/Power cut indication for the freezer section	●/-	●/-
Acoustic door alarm/Acoustic temperature alarm	●/-	●/-
Optical door alarm/Optical temperature alarm	●/-	●/-
Technical data		
Dimensions in cm (W x H x D) (Recess dimensions for integrated units)	56 – 56.8 x 177.2 – 178.8 x 55.5	56 – 56.8 x 177.2 – 178.8 x 55.5
Sound power in dB(A)	34	38
Storage time in event of a fault	-	-
Accessories supplied		
Cool pack/ice tray	-	-



Built-in Fridge Freezers

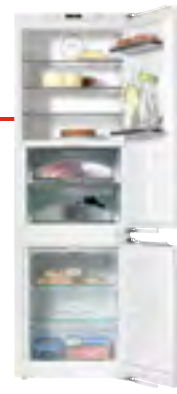
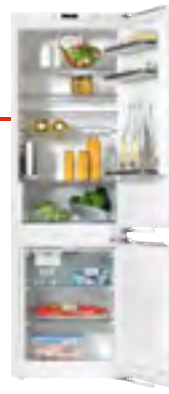

Model	KFNS 37432 iD	KFNS 37452 iDE	KFNS 37682 iD
Appliance category			
Refrigerator/Freezer/Fridge Freezer	-/-●	-/-●	-/-●
Type of appliance			
Freestanding/Integrated	-/●	-/●	-/●
Door hinging/Convertible	Right/●	Right/●	Right/●
Side-by-side compatible/Side-by-side location	●/Freely combinable	●/Freely combinable	●/Freely combinable
Design			
Colour/front	-/-	-/-	-/-
Lighting in refrigerator/PerfectFresh/Freezer section	●/-/-	●/-/-	●/●/-
Type of lighting	FlexiLight	FlexiLight	FlexiLight
Capacity			
Total gross volume	283	283	279
Refrigerator volume	202	202	126
PerfectFresh volume	-	-	72
Freezer volume	81	81	81
Freezing capacity (kg/24 h)	10	10	10
Convenience features			
PerfectFresh	-	-	-
PerfectFresh Pro	-	-	●
ComfortClean	●	●	●
DynaCool	●	●	●
SuperCool	●	●	●
SuperFreeze	●	●	●
NoFrost	●	●	●
VarioRoom	●	●	●
Active AirClean filter	-	-	-
SoftClose door damper	●	●	●
SelfClose	-	-	●
IceMaker/Plumbed in/MyIce water tank	-	●/-/●	-
EasyOpen lever handle	-	-	-
Refrigerator zone			
No. of shelves/Height adjustable/Sectionable/Illuminated	3/3/-/2	3/3/-/2	3/3/-/2
Chrome plated metal bottle rack	●	●	-
No. of removable vegetable drawers	1	1	-
Storage compartment for butter and cheese	-	-	-
VarioBord	●	●	●
No. of door racks/Door racks for bottles/Half door racks	3/1/-	3/1/-	2/1/-
PerfectFresh zone			
No. of PerfectFresh drawers	-	-	2
Freezer zone			
No. of freezer drawers	3	2+2	3
Controls			
Electronic temperature display and control	TouchControl	TouchControl	TouchControl
Efficiency and sustainability			
Energy efficiency rating	3.5	3	3
Energy consumption per year/in 24 h in kWh	300	336	335
Safety			
Control lock/Power cut indication for the freezer section	●/●	●/●	●/●
Acoustic door alarm/Acoustic temperature alarm	●/●	●/●	●/●
Optical door alarm/Optical temperature alarm	●/●	●/●	●/●
Technical data			
Dimensions in cm (W x H x D) (Recess dimensions for integrated units)	56 – 56.8 x 177.2 – 178.8 x 55.5	56 – 56.8 x 177.2 – 178.8 x 55.5	56 – 56.8 x 177.2 – 178.8 x 55.5
Sound power in dB(A)	37	37	38
Storage time in event of a fault	24	20	24
Accessories supplied			
Cool pack/ice tray	●	-	●





Model	KFNS 37692 iDE
Appliance category	
Refrigerator/Freezer/Fridge Freezer	-/-/●
Type of appliance	
Freestanding/Integrated	-/●
Door hinging/Convertible	Right/●
Side-by-side compatible/Side-by-side location	●/Freely combinable
Design	
Colour/front	-/-
Lighting in refrigerator/PerfectFresh/Freezer section	●/●/-
Type of lighting	FlexiLight
Capacity	
Total gross volume	279
Refrigerator volume	126
PerfectFresh volume	72
Freezer volume	81
Freezing capacity (kg/24 h)	10
Convenience features	
PerfectFresh	-
PerfectFresh Pro	●
ComfortClean	●
DynaCool	●
SuperCool	●
SuperFreeze	●
NoFrost	●
VarioRoom	●
Active AirClean filter	-
SoftClose door damper	●
SelfClose	●
IceMaker/Plumbed in/MyIce water tank	●/●/-
EasyOpen lever handle	-
Refrigerator zone	
No. of shelves/Height adjustable/Sectionable/Illuminated	3/3/-/2
Chrome plated metal bottle rack	-
No. of removable vegetable drawers	-
Storage compartment for butter and cheese	-
VarioBord	●
No. of door racks/Door racks for bottles/Half door racks	2/1/-
PerfectFresh zone	
No. of PerfectFresh drawers	2
Freezer zone	
No. of freezer drawers	2+2
Controls	
Electronic temperature display and control	TouchControl
Efficiency and sustainability	
Energy efficiency rating	3
Energy consumption per year/in 24 h in kWh	340
Safety	
Control lock/Power cut indication for the freezer section	●/●
Acoustic door alarm/Acoustic temperature alarm	●/●
Optical door alarm/Optical temperature alarm	●/●
Technical data	
Dimensions in cm (W x H x D) (Recess dimensions for integrated units)	56 – 56.8 x 177.2 – 178.8 x 55.5
Sound power in dB(A)	38
Storage time in event of a fault	20
Accessories supplied	
Cool pack/ice tray	-



Built-in Freezer



Model	FNS 37402 i
Appliance category	
Refrigerator/Freezer/Fridge Freezer	-/●/-
Type of appliance	
Freestanding/Integrated	-/●
Door hinging/Convertible	Right/●
Side-by-side compatible/Side-by-side location	●/Freely combinable
Design	
Colour/front	-/-
Lighting in refrigerator/PerfectFresh/Freezer section	-/-/●
Type of lighting	LED
Capacity	
Total gross volume	248
Refrigerator volume	-
PerfectFresh volume	-
Freezer volume	248
Freezing capacity (kg/24 h)	18
Convenience features	
PerfectFresh	-
PerfectFresh Pro	-
ComfortClean	-
DynaCool	-
SuperCool	-
SuperFreeze	●
NoFrost	●
VarioRoom	●
Active AirClean filter	-
SoftClose door damper	●
SelfClose	-
IceMaker/Plumbed in/MyIce water tank	-
EasyOpen lever handle	-
Refrigerator zone	
No. of shelves/Height adjustable/Sectionable/Illuminated	-
Chrome plated metal bottle rack	-
No. of removable vegetable drawers	-
Storage compartment for butter and cheese	-
VarioBord	-
No. of door racks/Door racks for bottles/Half door racks	-
PerfectFresh zone	
No. of PerfectFresh drawers	-
Freezer zone	
No. of freezer drawers	8
Controls	
Electronic temperature display and control	TouchControl
Efficiency and sustainability	
Energy efficiency rating	3
Energy consumption per year/in 24 h in kWh	331
Safety	
Control lock/Power cut indication for the freezer section	●/●
Acoustic door alarm/Acoustic temperature alarm	●/●
Optical door alarm/Optical temperature alarm	●/●
Technical data	
Dimensions in cm (W x H x D) (Recess dimensions for integrated units)	56 – 56.8 x 177.2 – 178.8 x 55.5
Sound power in dB(A)	38
Storage time in event of a fault	34
Accessories supplied	
Cool pack/ice tray	●



Wine Conditioning



Model	KWT 6321 UG	KWT 6831 SG
Appliance category		
Wine conditioning	●	●
Type of appliance		
Freestanding/Built under	-/●	●/-
Door hinging/Convertible	Right/●	Right/●
Design		
Colour/front	Glass door/Handle strip	Framed glass door
Lighting	●	●
Type of lighting	LED (dimnable)	LED
Convenience features		
No. of wine conditioning zones	2	3
No. of Bordeaux bottles	34	178
No. of storage levels	5	13
No. of wooden racks	3	10
No. of flexible wooden racks with FlexiFrame	-	10
DynaCool	●	●
Active charcoal filter	●	●
SoftClose door damper	-	●
Bottle presenter	-	●
Controls		
Electronic temperature display and control	ComfortControl	TouchControls
Safety		
Control lock/Power cut indication	●/●	●/●
Acoustic door alarm/Acoustic temperature alarm	●/●	●/●
Optical door alarm/Optical temperature alarm	-/-	●/●
Technical data		
Dimensions in cm (W x H x D)	59.7 x 81.87 x 57.5	70 x 192 x 74.5
Sound power in dB(A)	40	38



Using refrigerators, freezers and wine units to their best avail

For a perfectly hygienic refrigerator

Many different types of food are stored in a refrigerator, some of which, such as cheese, may smell.

However, food should be stored not only in a cool, but also in an odour-neutral environment. The Active AirClean filter from Miele, with active charcoal, absorbs odours and prevents the transfer of odours onto other foods. It also eliminates the unpleasant aromas experienced when opening the door.



Accessories for refrigerators, freezers and wine units



Insulation panels for freezers. IP 600

- For reducing energy consumption
- For separating unused from used areas
 - Saves up to 50% energy in unused areas
 - For FN12.000/14.000 freezers

IP 600: for 60 cm wide freezers
M.-Nr. 6.522.590

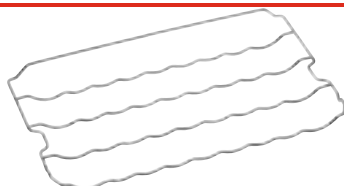

Bottle rack KFR 30060 PF / KFR 30060

- Made from chrome-plated metal for the horizontal storage of up to five bottles
- For built-in K30.000 refrigeration series

KFR 30060 PF for appliances with PerfectFresh
M.-Nr. 9.552.700
KFR 30060 for appliances without PerfectFresh
M.-Nr. 9.552.690



FlexiLight light strip

- For a perfectly illuminated refrigerator
- For fitting onto the front of the glass shelves
 - With 3 LEDs
 - Contents: 1 pre-configured light unit
 - Suitable for K30.000 refrigerator series

M.-Nr. 9.552.720



Bottle rack KFR 10061

- Made from chrome-plated metal for the horizontal storage of up to five bottles
- For 60 cm wide K10.000 freestanding refrigeration appliances without PerfectFresh

M.-Nr. 7.316.080



Bottle rack KFR 10067

- Made from chrome-plated metal for the horizontal storage of up to five bottles
- For 60 cm wide K10.000 freestanding refrigeration appliances with PerfectFresh

M.-Nr. 7.316.090

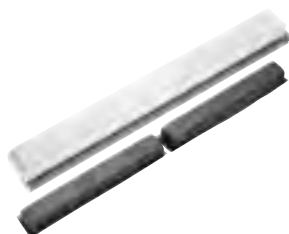

Retrofitting kit for Active AirClean filter KKF-FF

- Prevents unpleasant odours in the refrigerator
- For optimum and odour-neutral food storage conditions
 - Innovative combination of active charcoal with chitosan
 - To be fitted onto the rear edge of the glass shelves
 - Recommended replacement: approx. every 6 months
 - Only the two filters require replacing (KKF-RF, M.-Nr. 7.236.280)
 - Retrofittable on all K9.000 and K 30.000 built-in and K12.000 freestanding appliances
- M.-Nr. 7.236.290



Odour-absorbing Active AirClean filter KKF-RF

- Contents: 2 odour filters
- For filter replacement in plastic housing of KKF-FF (Mat. no. 7.236.290)
 - Recommended replacement: approx. every 6 months
 - Suitable for K14.000 and KFN14.000 models. Retrofittable on all K9.000 and K30.000 built-in and K12.000 freestanding appliances.

M.-Nr. 7.236.280



Active AirClean filter

- For an odour-free climate in your wine conditioning unit
- For KWT 6321 UG built-under wine unit
 - For KWT 6831 SG freestanding wine unit

M.-Nr. 9.447.050

Installation diagrams

Correct installation and ventilation

The ventilation of your integrated or built under Miele refrigerator, freezer or wine conditioner is a very important factor that must be considered during installation. In order for your integrated or built under unit to operate correctly, all information outlined within the operating instructions regarding ventilation requirements must be adhered to. Incorrect installation and ventilation may cause unnecessary faults with your appliance that may not be covered under warranty.

*Please note that the outlined installation diagrams are based on minimum ventilation requirements

KFNS 37432 iD, KFNS 37452 iDE, KFNS 37682 iD

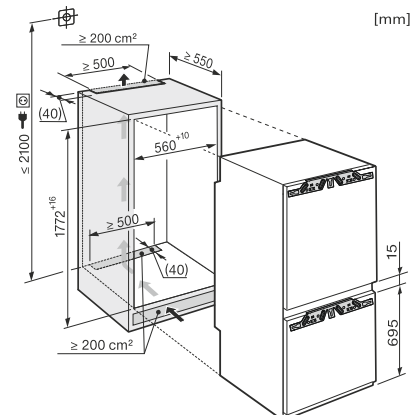

KS 37422 iD, KS 37472 iD, FNS 37402 i

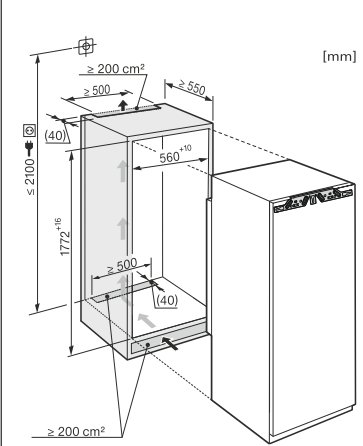

KFNS 37692 iDE

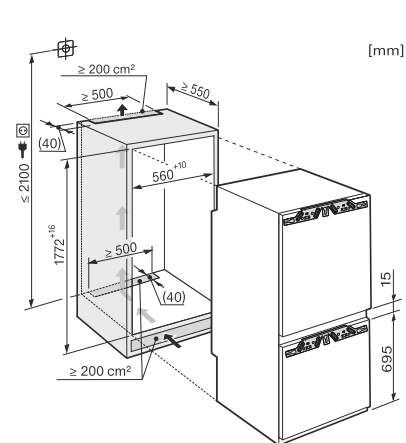

Installation possibilities to mains water KFNS 37692 iDE

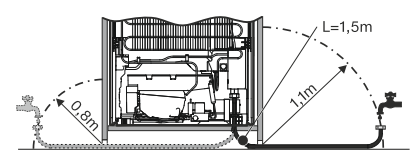

KWT 6321 UG

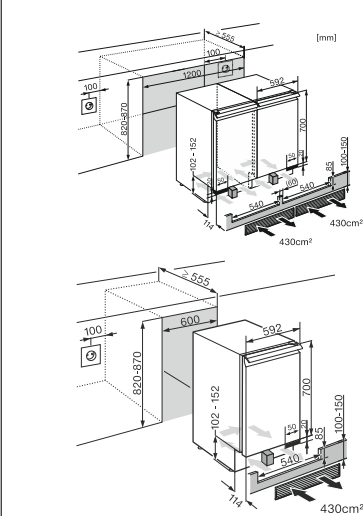



Useful information

Miele refrigerators, freezers and wine conditioning units - glossary

Active AirClean filters



Food should not only be stored somewhere cool, it should be stored in an odour free environment. This also applies to odour-free storage of wine. This is easily achieved with Miele's Active AirClean filters which contain an innovative and effective combination of active charcoal together with a natural product called chitosan. The filter is fitted simply and quickly.

CleanSteel



All machines in stainless steel have a special CleanSteel finish. The advantages: less visible fingerprints. CleanSteel is very easy to clean without the need for special detergents.

ComfortClean



Miele ComfortClean door racks are made from high-quality temperature resistant and transparent SAN plastic which is particularly scratch-proof and resistant to chemicals. All door racks on K 10000 and K 30000 appliances can also be washed conveniently and hygienically in a dishwasher (up to 55°C). Door racks no longer require manual cleaning.

DynaCool



Temperature and humidity are very important for the perfect storage of food and wine. With DynaCool, an integrated fan ensures that air circulates evenly, resulting in uniform temperature and humidity levels throughout the entire appliance.

EasyOpen lever handle



Miele refrigerators and freezers are particularly easily and elegant to open as they feature the ergonomical EasyOpen lever handle. Made from solid metal or stainless steel look for perfect design harmony right down to the very last detail. The design of your Miele refrigerator perfectly matches your other Miele built-in appliances.

FlexiFrame with NoteBoard



Every bottle rack features a magnetic strip for use with blackboard chalk: the strip is for noting, for example, a wine's origin, grape variety, year, etc. The NoteBoards are magnetically affixed; they can be removed and replaced easily for more convenient labelling. The versatile bottle racks from Miele offer the perfect hold for every bottle. That is because the individual wooden slats can be repositioned within the frame and adjust perfectly to different types of bottles. This provides the perfect storage position for your wine bottles.

FlexiLight



The new LED FlexiLight glass-edge lighting not only illuminates the interior of Miele appliances with a glare-free and unique brilliance, it can also be positioned wherever needed. This ensures that no matter how much food you store, it cannot block the light and impair illumination. FlexiLight can be positioned where you need it most.

IceMaker



Ice-cold beverages served professionally and fast: the automatic IceMaker can produce approx. 100 ice cubes daily. Miele offers plumbed-in models as well as models with water container. You can fill the water container according to your needs.

LED lighting

The indirect lighting creates a pleasant atmosphere and underlines the high quality materials. LED lights are maintenance free and illuminate the internal cabinet perfectly. Compared with standard lightbulbs, LED lighting is particularly energy efficient and offers the benefit of a considerable longer life cycle.

NoFrost



The intelligent NoFrost system prevents the formation of ice on cabinet surfaces. This allows drawers to be opened and closed without ice formation causing an obstruction. NoFrost therefore saves considerable time and offers greater user convenience as manual defrosting is no longer required. The circulation of cool air in the freezer also prevents ice formation on frozen food.

PerfectFresh



In the PerfectFresh zone food can be kept fresh for much longer than in a conventional refrigeration unit. This ensures that important vitamins, minerals and freshness are retained longer.

PerfectFresh Pro



PerfectFresh Pro keeps fruit and vegetables fresh for even longer. Miele developed this innovative PerfectFresh technology further and achieved that food remains fresh for longer. In the PerfectFresh Pro drawer, fruit and vegetables are stored in ideal temperature and specific humidity levels.

SelfClose



The PerfectFresh drawers in Miele built-in appliances all have fully telescopic runners and a self closing mechanism with anti-slam feature. The drawers can be pulled out to their full depth and closed automatically again by a gentle touch. They are also extremely quiet and smooth-running. This high level of convenience provides easy access to all your stored food.

SoftClose



Refrigerator and freezer doors close silently and as if of their own accord: with SoftClose, the innovative anti-slam system from Miele. The door closes automatically when the opening angle is less than 30°. The SoftClose feature ensures that the door closes gently, preventing bottles in the door rack from rattling.

SuperCool/SuperFreeze

Miele refrigeration appliances offer additional convenience functions. SuperCool reduces the temperature to the lowest setting for 6 hours. Perfect for cooling large quantities of food quickly. In SuperFreeze, the freezer is running at full power. Freezing food fast preserves nutrients excellently and retains the foods' texture as the formation of ice crystals is prevented.

Temperature zones



Miele wine units feature up to three sections with separate temperature controls. Up to three different types of wine such as red wine, white wine, Champagne or sparkling wine can be conditioned at the same time.

VarioBord

The high-quality, elegant VarioBord service racks are easy to remove from the stainless-steel holders in the door and are just as easily replaced. The VarioBord door-rack system has a handle and can be taken from the fridge to the table for serving.

VarioRoom



The VarioRoom storage concept allows you to arrange storage space in the freezer to suit your needs. This is particularly useful when you have something tall or bulky to freeze. By simply removing glass shelves and drawers you have plenty of space for that awkward item.

Miele Australia Pty. Ltd.

ACN 005 635 398
ABN 96 005 635 398

Miele Australia Pty. Ltd.

Head Office
1 Gilbert Park Drive
Knoxfield VIC 3180

Telephone 1300 4 MIELE (1300 464 353)

Miele Center Knoxfield

1 Gilbert Park Drive
Knoxfield VIC 3180

Miele Center South Melbourne

206-210 Coventry Street
South Melbourne VIC 3205

Miele Center and Office Sydney

3 Skyline Place
Frenchs Forest NSW 2086

Miele Center and Office Brisbane

39 Harvey Street North
Eagle Farm QLD 4009

Miele Center and Office Adelaide

83 Sir Donald Bradman Drive
Hilton SA 5033

Miele Center and Office Perth

205-207 Stirling Highway
Claremont WA 6010

www.miele.com.au

Miele New Zealand Limited**Miele Center and Head Office**

8 College Hill
Freemans Bay, Auckland, 1011
Telephone 0800 264 353

www.miele.co.nz

Miele Global Headquarters**Miele & Cie. KG**

Carl-Miele-Strasse 29
D-33332 Gütersloh
Federal Republic of Germany

Foreign Sales Companies

(A)	Miele Ges.m.b.H., Wals/Salzburg
(AUS)	Miele Australia Pty. Ltd., Melbourne
(B)	N.V. Miele S.A., Mollem
(CDN)	Miele Limited, Vaughan/Ontario
(CH)	Miele AG, Spreitenbach
(CL)	Miele Electrodomésticos Ltda., Santiago de Chile
(CN)	Miele Shanghai Trading Ltd., Shanghai
(CZ)	Miele spol.s.r.o., Brno
(D)	Miele & Cie. KG, Gütersloh
(DK)	Miele A/S, Glostrup/Copenhagen
(E)	Miele S.A., Alcobendas/Madrid
(EST)	Miele SIA Eesti filiaal, Tallinn
(F)	Miele S.A.S., Le Blanc-Mesnil/Paris
(FIN)	Miele Oy, Vantaa/Helsinki
(GB)	Miele Company Ltd., Abingdon
(GR)	Miele Hellas E.P.E., Psychiko-Athens
(H)	Miele Kft., Budapest
(HK)	Miele Hong Kong Ltd., Hong Kong
(HR)	Miele d.o.o., Zagreb
(I)	Miele Italia S.R.L., Eppan
(IND)	Miele India Pvt Ltd., New Delhi
(IRL)	Miele Ireland Ltd., Dublin
(J)	Miele Japan Corp., Meguro-ku/Tokyo
(KZ)	Miele Liability Partnership, Almaty
(L)	Miele s.à r.l., Luxembourg
(LT)	SIA "Miele" Lietuvos filialas, Vilnius
(LV)	Miele SIA, Riga
(MAL)	Miele Sdn Bhd, Kuala Lumpur
(MEX)	Miele S.A. de C.V., Mexico City
(N)	Miele AS, Nesbru/Oslo
(NL)	Miele Nederland B.V., Vianen
(NZ)	Miele New Zealand Ltd., Auckland
(P)	Miele Portuguesa Lda., Carnaxide/Lisbon
(PL)	Miele Sp. z o. o., Warsaw
(RO)	Miele Appliances S.R.L., Otopeni
(ROK)	Miele Korea Ltd., Seoul
(RU)	000 Miele CIS, Moscow
(S)	Miele AB, Solna/Stockholm
(SGP)	Miele Pte. Ltd., Singapore
(SK)	Miele spol.s.r.o., Bratislava
(SLO)	Miele d.o.o., Ljubljana
(SRB)	Miele d.o.o., Belgrade
(TR)	Miele Elektrikli Aletier, Levent/Istanbul
(UA)	Miele LLC, Kiev
(UAE)	Miele Appliances Ltd., Dubai
(USA)	Miele, Inc., Princeton/New Jersey
(ZA)	Miele (PTY) Ltd., Bryanston/Johannesburg



www.miele-shop.com