

MasterCool
Refrigerators, freezers and wine conditioning units



Welcome to Miele



IMMER BESSER (forever better) – our pledge

When our two great grandfathers were in the process of founding the Miele company, they had to make sure they stood apart from the competition in order to be successful. There are effectively only two ways of doing this: either by being cheaper than the rest or by being better than the rest. It is not really possible to be both at the same time.

They decided to be “better“ than the rest.

Numerous best in class awards and certificates attest to the fact that Miele has continued to renew its commitment to being “immer besser“ throughout the past 115 years. However, the millions of satisfied customers around the world are perhaps the most important endorsement.

At the heart of this success lies a continuity of values and goals which are typically only found in companies which have been family-run for generations, rather than in businesses which are guided by the often short-term interests of the stock market.

It is in this sense that Miele has embodied first-class product quality and German engineering since 1899. Miele also stands in equal measure for respect, fairness and mutual esteem towards sales partners, customers, suppliers, employees and neighbours. Buying a Miele is an environmentally friendly decision. We ensure this by using methods of production that save resources as well by producing products which set new standards in terms of their consumption of electricity, water and detergent – and save you money at the same time.*

As directors and co-proprietors of the fourth generation of our business we promise you that this will not change.

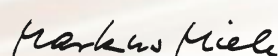

Dr. Markus Miele



Dr. Reinhard Zinkann

* Please visit www.miele-sustainability.com for more information on our efforts and guiding principles

IMMER BESSER

Our brand promise

There are many good reasons for choosing Miele.

Here are just six of them.

Since the company was founded in 1899, Miele has remained true to its ‚Immer Besser‘ brand promise. This means that we will do all that we can to be ‚forever better‘ than our competitors and ‚forever better‘ than we already are. For our customers this means the peace of mind of knowing that choosing Miele is a good decision – and probably the decision of a lifetime!



The Miele brand

In many countries, Miele is the most desired brand in its field. In its German home market, Miele was even voted ‚best brand ever‘ in 2013 across all product branches. And the ownership of products from such a brand reveals much about its users: Miele customers have high expectations for the performance, convenience, design and the environmental friendliness of their domestic appliances. People who buy Miele are quality conscious and have style!



Miele quality

For more than 100 years it has been a proven adage that you can trust Miele and rely on our appliances. We are the only manufacturer in our branch of industry to test products such as our washing machines, tumble dryers, dishwashers and ovens to the equivalent of 20 years of use. Once a Miele, always a Miele: Miele customers around the world remain loyal to Miele and recommend Miele to others. Looking to the future, we promise not to entertain any compromises when it comes to quality and durability!



Miele technology

Miele stands for excellent results combined with the lowest possible energy consumption. This goes for the hygienic and gentle care of your laundry, your flooring and your crockery as well as when conjuring up exquisite culinary delights. The key to this is a wealth of innovative features available only from Miele. This is borne out by numerous first places in leading product tests conducted around the world.



Miele convenience

Whether conventional rotary switch, discreet sensor controls or a high-resolution touch display like the one on your smartphone: operating a Miele is both easy and fun. Add to this a multitude of convenient and reliable automatic programmes and a great love of detail - success is guaranteed - on board both laundry and kitchen appliances. Make life easier for yourself with Miele!



Miele design

Miele believes in clean lines and timeless elegance. Nowhere else will you find such a comparable range of built-in kitchen appliances, with consistency in Design lines and colour options, to suit the most diverse of interior designs and kitchen furniture fronts. Great care is taken to coordinate appliance design across the range. Whatever the style of your kitchen: Miele is the perfect match.



Miele service

Miele customers enjoy preferential treatment: thanks to our fast and efficient after-sales service operation which has been voted best in its branch of industry many times over. We will always be there for you. That's a promise!

Wide variety of appliances for modern lifestyles

Contents

Introduction

Welcome to Miele	2
Our pledge	3-5
Variety of appliances	6-9
Design, innovation and convenience	10-17
Product highlights	18-21
Model range	22-23
Accessories	24-25
Installation diagrams	26-27
Further information	
Glossary	28





With its refrigeration appliances, Miele offers a wide variety of models equipped with state-of-the-art technology and unique convenience. Every appliance was designed specifically for its purpose and to meet the highest of demands in terms of quality and durable functionality. The exceptional Miele design is easily recognisable – high-quality materials and clear lines throughout the entire appliance. That is Miele.

Wide variety of appliances for modern lifestyles

The designs of Miele refrigerators, freezers and wine conditioning units



Miele appliances inspire with special highlights by ensuring that all types of food is kept fresh, frozen or stored under ideal conditions. MasterCool or classic built-in and freestanding appliances - enjoy the benefits of completely new convenience features.



Refrigerators

Miele refrigerators are designed to keep your groceries fresh in an efficient and well organised way. Intelligent MasterFresh compartments guarantee that food is kept fresh expertly.



Fridge-freezers

These appliances offer plenty of storage space for fresh food and also for frozen food, each section with its own door. Miele fridge-freezer combinations combine convenient, gentle storage of fresh food as well as frozen food in one appliance.



Freezers

Miele freezers are powerful and efficient, and exemplary in terms of organisation and functionality. They can be set up as stand-alone appliances or excellently combined with a matching Miele refrigerator as a side-by-side installation.



Wine conditioning

Miele wine units provide the optimum storage conditions for your wine collection. With individually controlled temperature zones for different types of wine, your reds and whites are guaranteed professional treatment. Not only does a Miele wine conditioning unit provide the best storage conditions for your wine, it will also look the part in your home.

Design, innovation and convenience

With the development of the large-capacity MasterCool appliances, Miele sets new standards. High-end design, impressive innovations and inimitable convenience features are combined in refrigeration appliances of the highest calibre. Enjoy the benefits of completely new convenience features.





Impressive look

The formidable appearance of MasterCool appliances give you an idea of the precision and devotion that was applied when selecting and working the materials. The inimitable appearance reflects the extreme attention to detail.

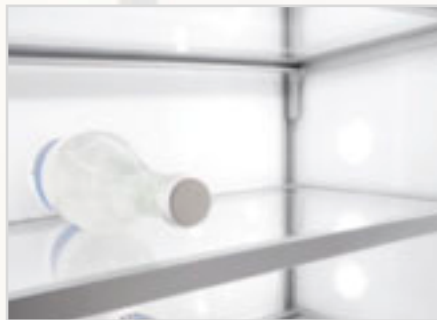

Unsurpassed quality

Perfection and precision of the highest quality. This begins when selecting the right materials. High-quality glass shelves, scratch-proof plastic and solid aluminium frames characterise the highest quality. Knowledge and experience are the best advisors on the path to high-end products.



Design at its best

The unique interior features leave nothing to be desired. Horizontal lines emphasise the puristic design. The smooth, white painted side panels inside the appliance are easy to clean and contribute to perfect, glare-free illumination.



Maximum convenience

MasterCool appliances offer the best in terms of convenience each and every day, such as ideal food storage conditions, dispensing of ice and water, a BrilliantLight concept and fast and convenient handling. MasterCool appliances meet exacting requirements of your everyday needs.



Wide variety of large-capacity appliances

All models from Miele are available as a MasterCool version – from refrigerator to wine units, with no limits on combination possibilities, the customer choice is diverse.

Revolutionary user interface

The MasterCool control system of Miele refrigerators, freezers and wine conditioning units

One of the most revolutionary aspects of MasterCool is found in the user interface. With most cooling appliances, the user is expected to have an elevated knowledge of the adequate temperature and humidity levels needed to preserve and protect their diverse range of food items. Meat, cheese, produce, even seafood, all demand unique environmental storage conditions in order to be kept fresh and flavourful. Milk, for example, is stored perfectly at 4°C, while vegetables require a temperature just above freezing. When it comes to humidity control, meat, fish, dairy and deli items last longer in a drier environment than fruits and vegetables.

In reality, most people are unfamiliar with how to properly set these levels given the ambiguity of user controls. When Miele's MasterCool control system is activated, the user is greeted with a food-driven menu system that is easy to view, understand and adjust for each of its independent cooling zones. This intuitive functionality helps to create and maintain the optimum conditions required for specific food categories so freshness is locked in. Now that's some cool, useful technology.

The Miele logo is printed in a large, bold, dark blue font on the surface of a refrigerator door. The door is light-colored and has a horizontal vent or handle area visible above the logo. The background of the entire page is a blurred image of a kitchen interior with a window and a refrigerator.



MasterFresh

Pure enjoyment and natural taste!

Purchased when fresh – but how do you retain the freshness?

Fresh food is the basis for wholesome, healthy living. Fruit and vegetables should be consumed as crisp and fresh as when purchased. But who has the time nowadays to buy ingredients fresh every day?

Apart from the quality of the food at the point of purchase, the right storage conditions are also important. The storage conditions determine how fresh, tasty and healthy food still is when preparing it for consumption. This is easily achieved with MasterFresh.

Clever cooling – healthy eating

MasterFresh is the synonym for innovative food storage at Miele: a special cooling zone in Miele refrigerators which offers ideal storage conditions for a variety of food. Thanks to the MasterFresh zone, many types of fruit and vegetables, meat, fish and milk products remain fresh considerably longer than in conventional refrigerators. At a temperature of between 0°C and 3°C, as well as ideal humidity levels, even sensitive food can be stored in ideal conditions and retain its freshness. Important vitamins and minerals are retained longer. Freshness you can see and taste!



Miele



Freshness retained longer than in a refrigerator

Foods such as meat, fish and dairy products are ideally stored in a dry place. The low temperature between 0°C and 3°C ensures that your food remains fresh and retains its high quality for a long time. In other words, less frequent trips to the shop and less waste, saving time and money for other nice things.

Tip: store food in its packaging or covered, allowing moisture to remain inside the food and preventing the transfer of flavours and odours.

Use all your senses to ensure that the food is of high quality – independently from the best before date.

Food (examples)	Freshness retained longer than in refrigerator
Butter, yeast, sliced meat	Up to 1 week
Cream, butter milk	Up to 2 weeks
Yoghurt, soft cheese	Up to 3 weeks

Food remains fresh up to 4 months longer than in a conventional refrigerator

Fruit and vegetables require high humidity storage conditions. Stored at low temperatures and high humidity levels, your food remains fresh for longer.

Filling the drawer with fresh fruit and vegetables creates humidity which is maintained thanks to a special Miele design. This results in, for example, apples staying fresh for up to 4 months longer than when stored in a conventional refrigerator. Fresh fruit and vegetables always available from your refrigerator – crisp and tasty as if fresh from the market.

Tip: place fruit and vegetables in their packaging in the drawer to allow humidity to develop. To ensure that a sufficient humidity level develops, the compartment should always be well stocked.

Food (examples)	Freshness retained longer than in refrigerator
Lettuce, mushrooms, onions, strawberries, blueberries, nectarines	Up to 1 week
Asparagus, kale, Mirabelle plums, plums, rhubarb, peaches, morello cherries	Up to 2 weeks
Pears, apples, carrots	Up to 4 months

Miele wine conditioning units

Wine storage with style and many highlights





As much as you treasure your valuable collection of wines, we treasure the technology that protects it. Our dynamic cooling systems safeguard your wines from unwanted fluctuations in temperature, humidity and vibration. In Miele's full sized wine storage unit, three unique cooling zones, each with independent controls, are available to store or temper champagne and wine (white or red) at their ideal environmental condition.

Miele highlights for perfect results and more convenience

The product highlights* of Miele refrigerators, freezers and wine conditioning units



MasterFresh

Apart from the quality of the food at the point of purchase, the right storage conditions are also important. The storage conditions determine how fresh, tasty and healthy food still is when preparing it for consumption. This is easily achieved with MasterFresh: perfect storage conditions for fresh food to retain vitamins, nutrients and flavours!

**BrilliantLight**

Soft light: halogen spotlights illuminate all areas inside the refrigerator in style.

**DynaCool**

Uniform distribution of temperature: a ventilator ensures excellent circulation and distribution of cold air.

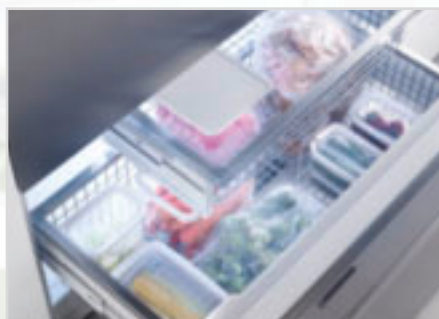
**NoFrost**

Convenient: manual defrosting no longer necessary. Cooled air is circulated and prevents the formation of ice on food.

**Drop and Lock**

Easy handling and safe: the metal door compartments are height adjustable and easily locked in place.

**Ice/Water dispenser**

Pure luxury: at the touch of a button you are treated to refreshing ice and water from the through-the-door Ice/Water Dispenser

Further convincing talents

The product benefits* of Miele refrigerators, freezers and wine conditioning units



Exclusive to Miele **TouchControl**
Precise temperature control: a fascia panel with a smooth interface enables users to set the exact required temperature



SuperCool/SuperFreeze
Fast cooling and freezing: ideal for large quantities of food, extra cold drinks or gentle freezing.



Acoustic warning signal
Automatic: a warning signal sounds when the door is left open, when the temperature rises beyond the critical level or after a power failure.



IceMaker
Produced quickly and stored: Miele's IceMaker has separate controls and can produce up to 150 ice cubes a day.



CleanSteel
No fingerprints on stainless steel: the surface is protected and no special cleaning agents are required.



Temperature zones
Separate temperature controls: up to three different types of wine requiring different temperatures can be stored at the same time.



Glass door
Perfect conditions: the tinted glass door protects wine from exposure to ultra-violet light and ensures that a perfect micro-climate is maintained.



MasterCool

Model range



Model/Sales designation	K 1801 Vi	F 1471 Vi	KF 1911 Vi
Appliance category			
Fridge/Freezer/Fridge-Freezer	●/-/-	-/●/-	-/-/●
Design			
Built-in/Integrated	●	●	●
Door hinging right/left	●/-	-/●	●/-
Door hinging convertible	●	-	●
MaxLoad door hinge 115° opening angle	Fixed	Fixed	Fixed
White lacquered aluminium interior	●	●	●
Controls	TouchControls	TouchControls	TouchControls
Electronic controls/Digital temperature display	●/●	●/●	●/●
Lighting	BrilliantLight	BrilliantLight	BrilliantLight
User convenience			
SuperCool	●	-	●
SuperFreeze	-	●	●
DynaCool	●	-	●
Tempered glass shelves with aluminium trim: fixed/adjustable	1/3	1/1	1/3
MasterFresh/Deli drawers	2/1	-	1/1
Full access freezer drawers	-	2	1 large/1 small
Drop&Lock door shelves/dairy compartment	3/1	1/-	2/1
IceMaker (requires plumbing)	-	In door: 1.5kg/24 h	Internal: 1.1kg/24 h
Visual/Acoustic alarm	●/●	●/●	●/●
Temperature range	2 to 8°C	-14 to -24°C	Fridge: 2 to 8°C/ Freezer: -14 to -24°C
Total usable capacity			
Refrigeration zone	376	-	362
MasterFresh zone	173	-	104
Freezer zone	-	495	176
Standard accessories			
Stainless steel water inlet hose	-	3 m	3 m
Water filter	-	KB 1000	KB 1000
Optional accessories			
Side-by-side fitting kit	KSK 1002	KSK 1002	KSK 1002
CleanSteel front panel	KFP 3003 ed/cs	KFP 1813 ed/cs	KFP 3613 ed/cs (upper)/ KFP 3623 ed/cs (lower)
Upper grille in white (left hand hinge)	KG 1082 w	-	KG 1092 w
Upper grille in white (right hand hinge)	KG 1083 w	-	KG 1093 w
Lower grille in stainless steel look	KG 1380 ss	KG 1140 ss	KG 1490 ss
Water filter with active charcoal	-	KWF 1000	KWF 1000
Dimensions and weight			
Niche height in mm	2134	2134	2134
Niche width in mm	762	457	915
Niche depth in mm	629	629	629
Appliance H x W x D in mm (excl. door front thickness)	2127 x 750 x 610	2127 x 445 x 610	2127 x 902 x 610
Appliance weight net/gross (kg)	189/211	139/149	225/249
Upper door weight (kg)/max. thickness in mm	50/19	65/19	38/19
Lower door weight (kg)/max. thickness in mm	-	-	14/19
Load bearing capacity of floor (kg)	452	228	537
Technical specifications			
Energy efficiency star rating	2	1.5	3
Energy consumption per year (kWh)	250	485	530
Voltage	220 – 240	220 – 240	220 – 240
Storage time in the event of a fault/Max. freezing capacity	-	13 h/14 kg	17 h/20 kg
Connected load (watts)	672	850	802
Noise levels in dB(A)re1pW	40	41	42



Model/Sales designation	KWT 1601 Vi
Appliance category	
Wine	●
Design	
Built-in/Integrated	●
Door hinging right/left	●/-
Door hinging convertible	●
MaxLoad door hinge 115° opening angle	Fixed
Triple glazed door with UV filter	●
Controls	TouchControls
Electronic controls/Digital temperature display for each zone	●/●
Lighting	BrilliantLight illumination + LED display lighting
User convenience	
SuperCool	●
DynaCool	●
No. of independently controllable zones	3
Wooden shelves: Fixed/FullAccess telescopic	2/12
Shelf labels/Bottle presenter	●/●
Vibration free storage	●
Active charcoal filters	●
Temperature range	3 to 18°C
Adjustable humidity levels	●
Total usable capacity	
Max. 0.75 litre Bordeaux bottles	102
Optional accessories	
Side-by-side fitting kit	KSK 1002
CleanSteel front panel	KFP 2403 ed/cs
Upper grille in white (left hand hinge)	07673741
Upper grille in white (right hand hinge)	-
Lower grille in stainless steel look	KG 1560 ss
Dimensions and weight	
Niche height in mm	2134
Niche width in mm	610
Niche depth in mm	629
Appliance H x W x D in mm (excl. door front thickness)	2127 x 597 x 610
Appliance weight net/gross (kg)	153/172
Upper door weight (kg)/max. thickness in mm	62/19
Lower door weight (kg)/max. thickness in mm	-
Load bearing capacity of floor (kg)	319
Technical specifications	
Energy efficiency star rating	-
Energy consumption per year (kWh)	-
Voltage	220 - 240
Connected load (watts)	340
Noise levels in dB(A)re1pW	42

Accessories for MasterCool appliances



Water filter with active charcoal filter KB 1000

For crystal clear and flavour-neutral ice cubes

- Filters taste and odour producing substances out of tap water
- For all plumbed-in MasterCool appliances with ice-cube maker

M.-Nr. 7.134.240



Water filter KWF 1000

For crystal clear ice cubes

- Holds back particulate contamination
- For all plumbed-in MasterCool appliances with ice-cube maker

M.-Nr. 7.134.220



For crystal clear freshness

Ice cubes should turn long drinks, aperitifs, cocktails and lemonade into cold and refreshing beverages without changing their flavour. To ensure that your Miele MasterCool appliances always prepare crystal clear and flavour-neutral ice cubes, Miele offers plumbed-in appliances with filters.



Stainless-steel front panel with CleanSteel finish - KFP 3003 ed/cs

For the attractive integration of MasterCool refrigerators into a kitchen

- For 75 cm wide refrigerators (K 1801 Vi)

M.-Nr. 9.883.390



Stainless-steel front panel with CleanSteel finish - KFP 1813 ed/cs

For the attractive integration of MasterCool freezers into a kitchen

- For 45 cm wide freezers with an ice cube/water dispenser in the door (F 1471 Vi)

M.-Nr. 9.883.370



Stainless-steel front panel with CleanSteel finish - KFP 3613 ed/cs

For the attractive integration of MasterCool fridge-freezer in a kitchen

- For the upper door on 90 cm wide fridge-freezer combinations (KF 1911 Vi)

M.-Nr. 9.883.480



Stainless-steel front panel with CleanSteel finish - KFP 3623 ed/cs

For the attractive integration of MasterCool fridge-freezer in a kitchen

- For the lower door on 90 cm wide fridge-freezer combinations (KF 1911 Vi)

M.-Nr. 9.883.490



Stainless-steel front panel with CleanSteel finish - KFP 2403 ed/cs

For the attractive integration of MasterCool wine units into a kitchen

- For 60 cm wide wine unit (KWT 1601 Vi)

M.-Nr. 9.883.380



**Lower plinth vent grille
KG 1140 ss**

In stainless-steel look for a high-end appeal of MasterCool plinth panels
• For 45 cm wide MasterCool freezer (F 1471 Vi)
M.-Nr. 7.182.380



**Lower plinth vent grille
KG 1560 ss**

In stainless-steel look for a high-end appeal of MasterCool plinth panels
• For 60 cm wide MasterCool wine conditioning unit (KWT 1601 Vi)
M.-Nr. 7.182.480



**Lower plinth vent grille
KG 1380 ss**

In stainless-steel look for a high-end appeal of MasterCool plinth panels
• For 75 cm wide MasterCool refrigerator (K 1801 Vi)
M.-Nr. 7.182.440



**Lower plinth vent grille
KG 1490 ss**

In stainless-steel look for a high-end appeal of MasterCool plinth panels
• For 90 cm wide MasterCool fridge-freezer (KF 1911 Vi)
M.-Nr. 7.182.470



**Upper grille section
KG 1082 w**

For door rehinging to the left on 75 cm wide MasterCool refrigerator (K 1801 Vi)
M.-Nr. 7.564.760



**Upper grille section
Model. N/A**

For door rehinging to the left on 60cm wide MasterCool wine conditioner (KWT 1601 Vi)
M.-Nr. 7.673.741



**Upper grille section
KG 1083 w**

For door rehinging to the right on 75 cm wide MasterCool refrigerator (K 1801 Vi)
M.-Nr. 7.564.770



**Upper grille section
KG 1092 w**

For door rehinging to the left on 90 cm wide MasterCool refrigerator/freezer (KF 1911 Vi)
M.-Nr. 7.564.780



**Upper grille section
KG 1093 w**

For door rehinging to the right on 90 cm wide MasterCool refrigerator/freezer (KF 1911 Vi)
M.-Nr. 7.564.790



**Side-by-side kit
KSK 1002**

For a high-quality side-by-side installation of MasterCool models
M.-Nr. 7.377.830

Installation diagrams

K1801Vi / KWT1601Vi

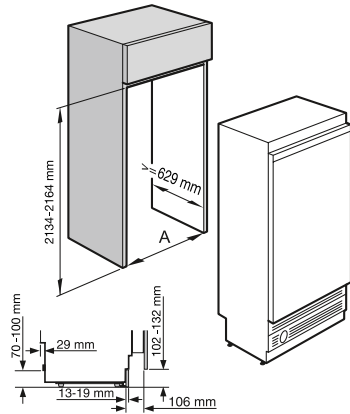

K 1801 Vi: A = 762 mm
KWT 1601 Vi: A = 610 mm

K1801Vi / KWT1601Vi

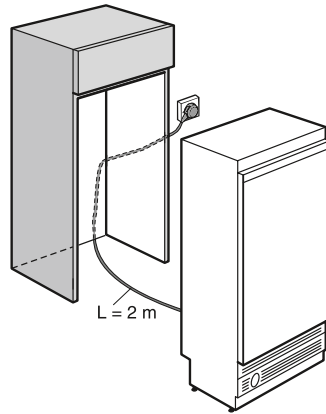

K1801Vi

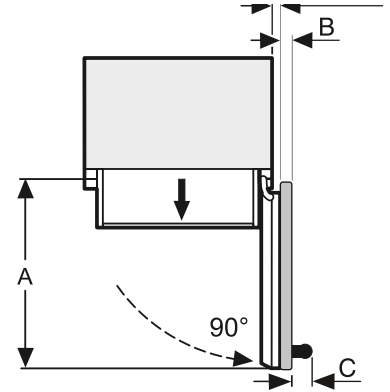

A = Appliance door width: 982 mm
B = Furniture front (max. 38 mm)
C = Door handle

K1801Vi

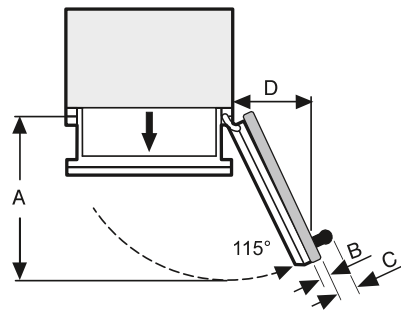

A = Appliance door width: 982 mm
B = Furniture front (max. 38 mm)
C = Door handle
D = Distance from appliance door to wall (without furniture door front and handle): 363 mm

F1471Vi

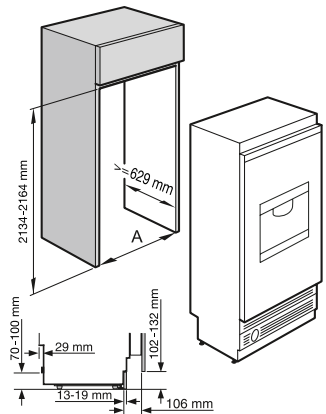

A = 457 mm

F1471Vi with KFP 1240 ss

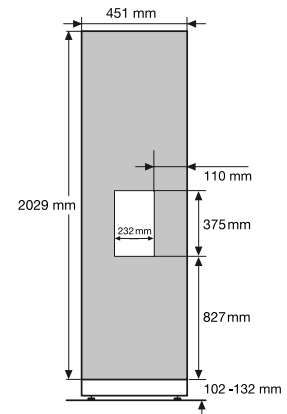

F1471Vi

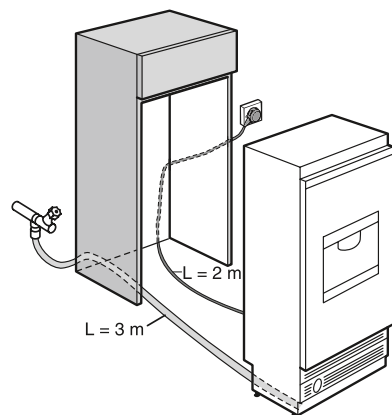

F1471Vi

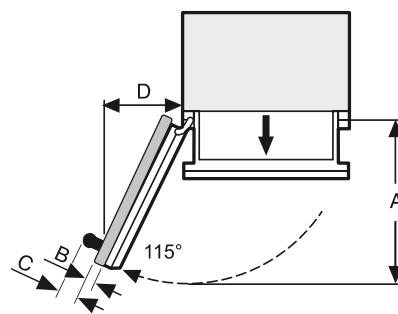

A = Appliance door width: 525 mm
B = Furniture front (max. 38 mm)
C = Door handle
D = Distance from appliance door to wall (without furniture door front and handle): 234 mm

Installation diagrams

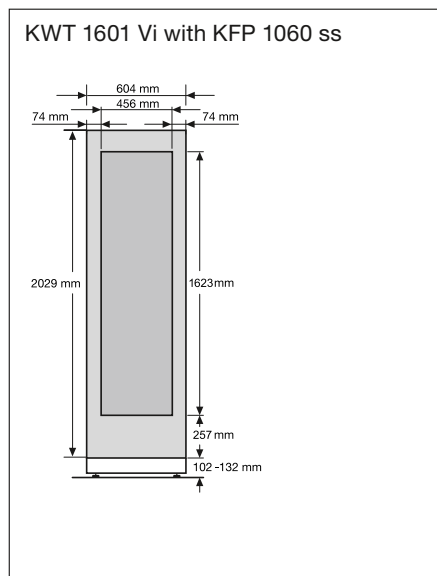
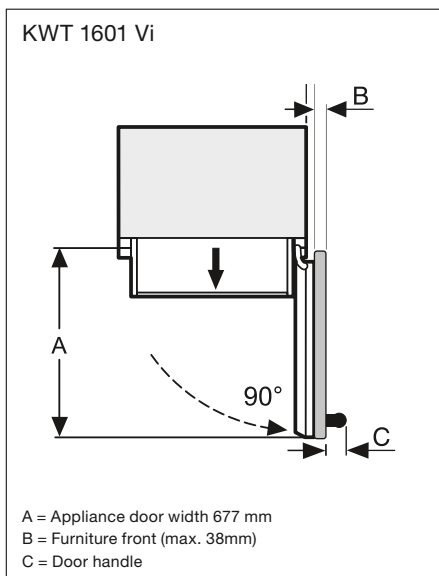
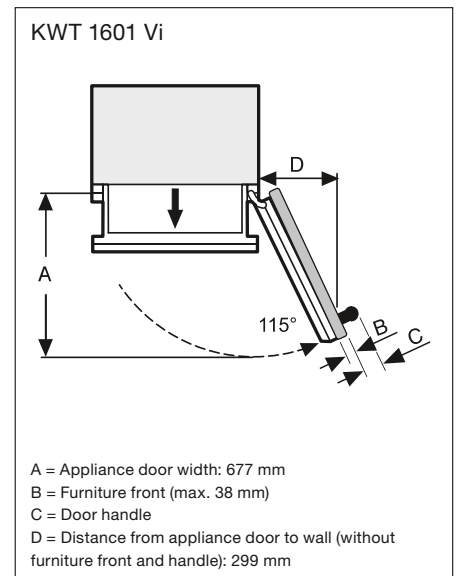
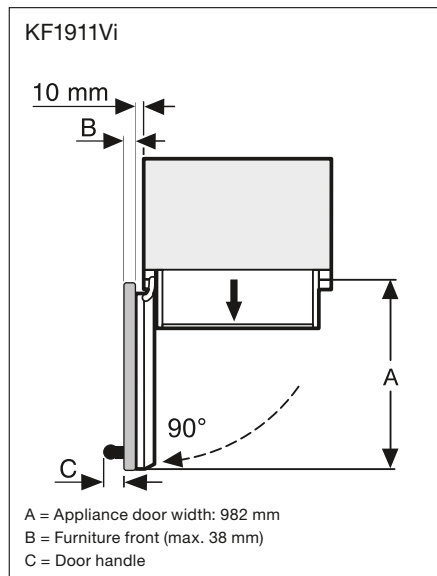
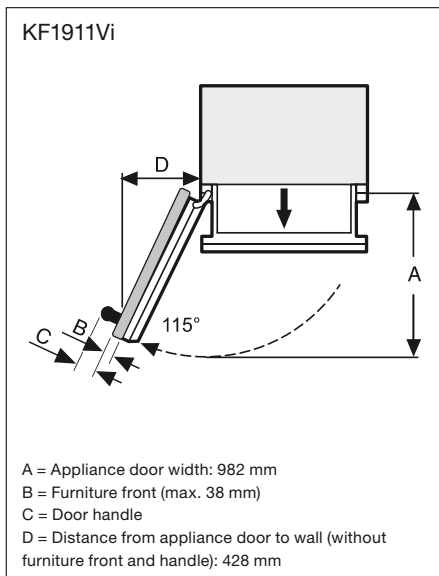
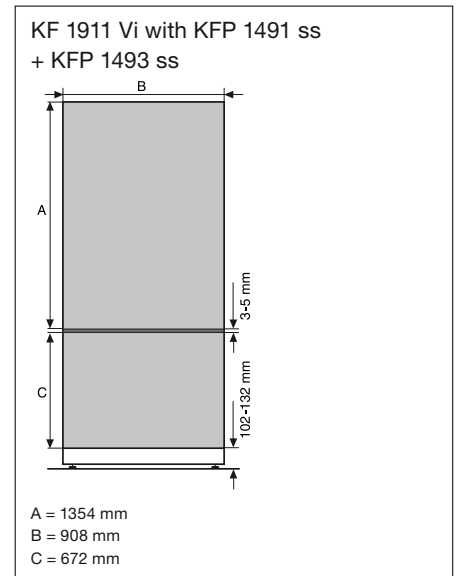
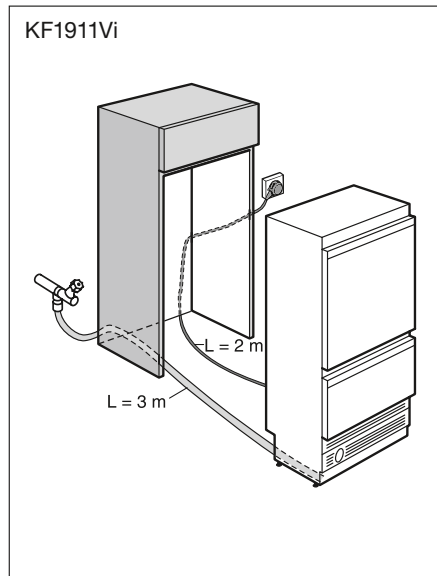
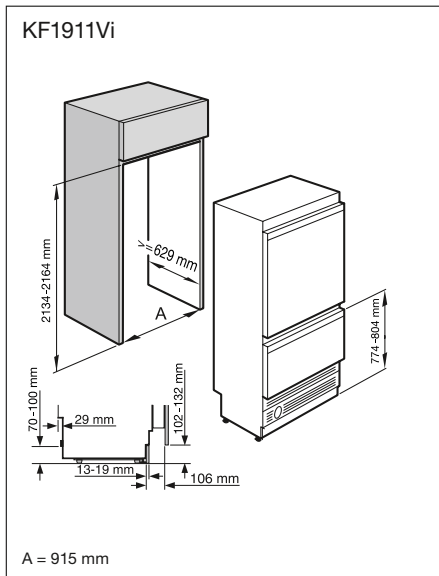

Useful information

Miele refrigerators, freezers and wine conditioning units - glossary

Acoustic warning signal

A warning signal sounds when the door is left open, when temperature rises beyond a critical level or after a power failure. This enables you to react quickly to prevent cooled food from getting too warm and frozen food from defrosting.

BrilliantLight



Multiple halogen spotlights illuminate the inner cabinet and reach into every corner of the appliance. Food is displayed in a pleasant, soft tone. The velvety sheen on the aluminium trim adds to the elegant appeal.

CleanSteel



All machines in stainless steel have a special CleanSteel finish. The advantage: less visible fingerprints.

CleanSteel is very easy to clean without the need for special detergents.

Drop and Lock



The metal door compartments are fully adjustable and ensure the highest possible flexibility. This well-designed principle of operation ensures particularly easy handling; the containers easily lock into place.

DynaCool



Temperature and humidity are very important for the perfect storage of food and wine. With DynaCool, an integrated fan ensures that air circulates evenly, resulting in uniform temperature and humidity levels throughout the entire appliance.

Glass door

A tinted triple-glazed break-proof glass door protects wine from harmful ultra-violet light. Also, efficient heat insulation reliably ensures that a required micro-climate is maintained. You cannot provide better storage conditions for your wine.

IceMaker



Ice-cold beverages served professionally and fast: the automatic IceMaker can produce up to 150 ice cubes daily.

Ice/Water dispenser

The 45 cm wide MasterCool freezer gives you superb convenient features: at the touch of a fingertip on the TouchDisplay you are served ice and water from the through-the-door dispenser. The integrated light provides atmospheric lighting in the kitchen if desired.

MasterFresh



In MasterCool drawers with controlled humidity levels, your food is stored in ideal conditions: the temperature is around 0°C and the humidity level adjusted to suit the needs of all types of food. This ensures that your food – particularly fruit and vegetables – remain fresh for longer.

NoFrost



The intelligent NoFrost system prevents the formation of ice on cabinet surfaces. This allows drawers to be opened and closed without ice formation causing an obstruction. NoFrost therefore saves considerable time and offers greater user convenience as manual defrosting is no longer required. The circulation of cool air in the freezer also prevents ice formation on frozen food.

SuperCool/SuperFreeze

Miele refrigeration appliances offer additional convenience functions. SuperCool reduces the temperature to the lowest setting for 6 hours. Perfect for cooling large quantities of food quickly. In SuperFreeze, the freezer is running at full power. Freezing food fast preserves nutrients and retains the foods' texture as the formation of ice crystals is prevented.

Temperature zones



Miele wine units feature up to three sections with separate temperature controls. Up to three different types of wine such as red wine, white wine, Champagne or sparkling wine can be conditioned at the same time.

TouchControl



The TouchControl fascia is positioned at an ergonomic height and features a smooth user interface with light-touch switches. The temperature can be selected with precision and is displayed digitally. This technical highlight also blends in with the elegant overall impression of the appliance – top-class design from Miele.



ACN 005 635 398
ABN 96 005 635 398
Miele Australia Pty Ltd

Head Office

1 Gilbert Park Drive
Knoxfield, VIC 3180
Telephone: 1300 4 MIELE (1300 464 353)

Miele Center Knoxfield

1 Gilbert Park Drive
Knoxfield, VIC 3180

Miele Center South Melbourne

206-210 Coventry Street
South Melbourne, VIC 3205

Miele Center and Office Sydney

3 Skyline Place
Frenchs Forest, NSW 2086

Miele Center and Office Brisbane

39 Harvey Street North
Eagle Farm, QLD 4009

Miele Center and Office Adelaide

83-85 Sir Donald Bradman Drive
Hilton, SA 5033

Miele Center and Office Perth

205-207 Stirling Highway
Claremont, WA 6010

Miele New Zealand Limited

IRD 98 463 631

Head office

Level 2, 10 College Hill
Freemans Bay, Auckland 1011

Telephone: 0800 4 MIELE (0800 464 353)

Miele Center Auckland
8 College Hill
Freemans Bay, Auckland 1011

Miele Global Headquarters

Miele & Cie. KG
Carl-Miele-Strasse 29
33332 Gütersloh
Federal Republic of Germany