

Miele
IMMER BESSER



Miele **MasterCool**

Contents

Introduction	Page 6
International Top Design	Page 12
Convenience	Page 16
Fresh innovations	Page 22
Model range	Page 28
Accessories	Page 50









A clear line for
the highest
demands.

Savouring the best things in life.

In keeping with our philosophy of “Immer Besser”, or “Forever better”, we came up with something special: the Miele MasterCool range of refrigeration. A product line of large capacity built-in appliances, which is incomparable in both function and quality. Mastercool combines the highest quality design, fascinating innovations and unequalled convenience in premium class refrigeration. Accompany us now on a journey into a new dimension and experience outstanding Miele quality in its greatest achievement.





The best for
your home.









International top design awards

Miele MasterCool pure Perfection

MasterCool appliances from Miele are state-of-the-art products designed to exceed the expectations of the discerning customer. Built according to Miele's philosophy of „Immer Besser“, this range of large capacity built-in appliances offers unique solutions for storing food and drink. Miele's MasterCool premium-class refrigeration appliances unite design, innovation and inimitable comfort, and it is this combination of elegance and functionality that has achieved numerous design awards. MasterCool: A new dimension in Miele quality.







Miele

The measure of all things: Quality.



Appearance

The sheer look of the huge MasterCool refrigerators prompts you to imagine the precision and dedication that went into choosing the individual materials used in these appliances. A boundless attention to detail that is reflected in its inimitable appearance.

- Materials which are uniform in colour
- No visible screws
- No visible slots

Quality

Precision and perfection towards the highest quality starts with the selection of the right materials. Knowledge and experience are a valuable guide on the path to premium-class products.

- High quality glass shelves
- Scratch-resistant polycarbonate door bins and drawers
- Aluminium frames
- Metal interior lining

Design

The high quality interior design of the Miele MasterCool appliances leaves nothing to desire. Sleek, white-painted walls support the perfect glare-free illumination of the interior and are easy to clean.

- Smooth walls
- Metal interior lining
- Glass shelves with aluminium frame
- Clean horizontal lines

Maximum convenience for the finest enjoyment

Miele MasterCool allows you to
enjoy life easily.

A decisive factor in this is the well
thought out interior that can offer the
best possible comfort day in, day out.
Whether this is with regards to optimal
food storage conditions or fast
operation, MasterCool excels in all
areas. This leaves you time to enjoy the
finer things in life.







The highest objective: Perfection.



BrilliantLight

Miele's unique BrilliantLight halogen system cascades light throughout the cabinet to illuminate the food in a soft light. The satin-smooth aluminium shelf trims add a further elegant touch.

- Unique lighting
- No blind or dark spots
- Lighting at all levels

Door interior

The clean line of high-quality interior is continued along the inside of the door. A look inside is enough to know one thing: precision is the guiding principle.

- Smooth interior doors
- Interior door storage compartments with aluminium frame
- Horizontal lines



Drop and Lock

Miele's Drop and Lock system uses a slide rail to move shelves and door fittings easily and conveniently in 1.5 cm increments using a one-handed "tilt and slide motion".

- Fully removable
- Flexible storage space with the Shelf management system
- Easy adjustability

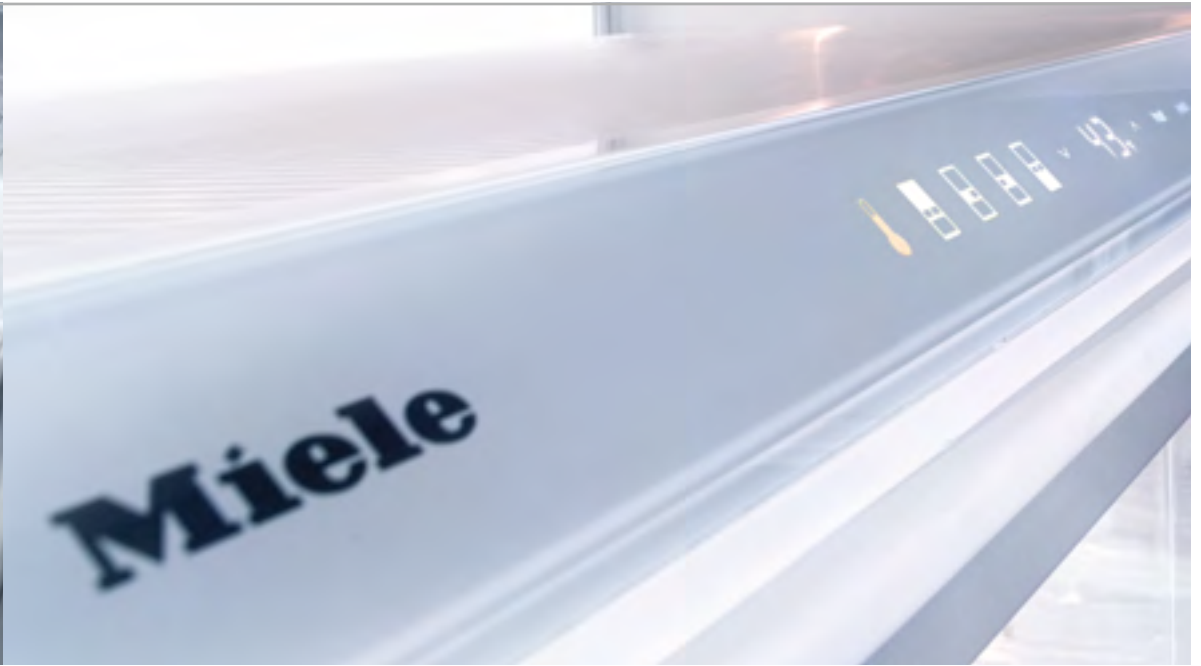

Full access storage drawers

Unique in quality and function. The drawers pull out completely for convenient loading, making it easier to find your favourite food quickly and without fuss.

- All drawers are fully extendable
- Easy to use
- Optimal view of contents



Intuitive controls

The ergonomically positioned Miele TouchControl electronic panel has a flat surface with sensor controls. The temperature can be regulated accurately by the degree and is displayed digitally. This technical highlight blends modestly into the elegant appearance – Miele design par excellence.

- Intuitive operation
- Ergonomic position
- LED lighting
- Precise temperature setting



Fresh innovations
for special
occasions.

**Miele MasterCool fulfills even the
greatest expectations.**

Captivating innovations harmonise perfectly to create something greater than the sum of its parts. MasterFresh for optimum temperature storage of food, and the ice and water dispenser, are just two of many attractive features which can make life as enjoyable as possible. The Miele MasterCool refrigeration series is full of other great ideas just waiting to be discovered.







Dynamic cooling

Thanks to the Dynamic cooling system, you can store food wherever you like in your MasterCool refrigerator. The fan situated at the back of the fridge circulates the cold air evenly around the cabinet, giving a constant temperature in all zones. Top or bottom – it's up to you



MasterFresh

In the humidity-controlled MasterFresh drawers, your food is always correctly stored. Because the temperature is maintained close to 0°C and humidity is individually optimised for each type of food, your food, particularly fruit and vegetables, will stay fresher for longer than if stored in a conventional refrigerator section.

- Food keeps fresh up to 3 times longer than normal
- Optimum quality is maintained
- Nutrients, texture and taste are maintained for longer



The major motivation: New ideas.



Ice and water dispenser

The 45 cm wide MasterCool freezer spoils you with a mere touch on the display, it serves you with a glass of iced water, or ice cubes for your drink, from the dispensing unit in the appliance door. The integrated lighting adds a hint of ambient character to your kitchen, if desired.

- Easy-touch control operation
- Ice cubes, crushed ice or chilled water
- Perfect illumination







The perfect temperature for your wine

A good wine needs time and the correct sustained climate conditions to mature, to allow its character to fully develop. A Miele wine conditioning unit will store your fine wines in ideal conditions, even different types of wine at the same time, because it has three separately adjustable temperature zones.

- Three separately controlled temperature zones
- Pull-out shelves made of acacia wood
- Built-in bottle presenter
- Triple glazed doors with UV protection
- LED interior lighting



		Appliance width				
	Gross volume	45 cm	60 cm	75 cm	90 cm	Door hinging
Refrigerators	549 litres			 K 1801 Vi		right
Freezers	From 250 to 495 litres	 F 1471 Vi		 F 1811 Vi		left
Fridge/ Freezer combination	642 litres				 KF 1911 Vi	left
Wine	102 Bottles (750 ml Bordeaux style bottles)		 KWT 1601 Vi			right

Infinite combination options

**Miele MasterCool offers
many possibilities.**

The range not only covers all types of models from refrigerators to the wine conditioner, but also many different widths and door hinging options. With all these combination choices, MasterCool refrigeration has virtually no limits. Individuality is paramount!





Welcome to
a new
dimension
in cooling.

MasterCool is like a virtual journey of
infinite space.

A unique product range whose size is
not only measured in numbers but also
in its grand effect. Miele MasterCool
is a captivating wonder of space in
accomplished perfection.

MasterCool refrigerator K 1801 Vi.



Installation diagram

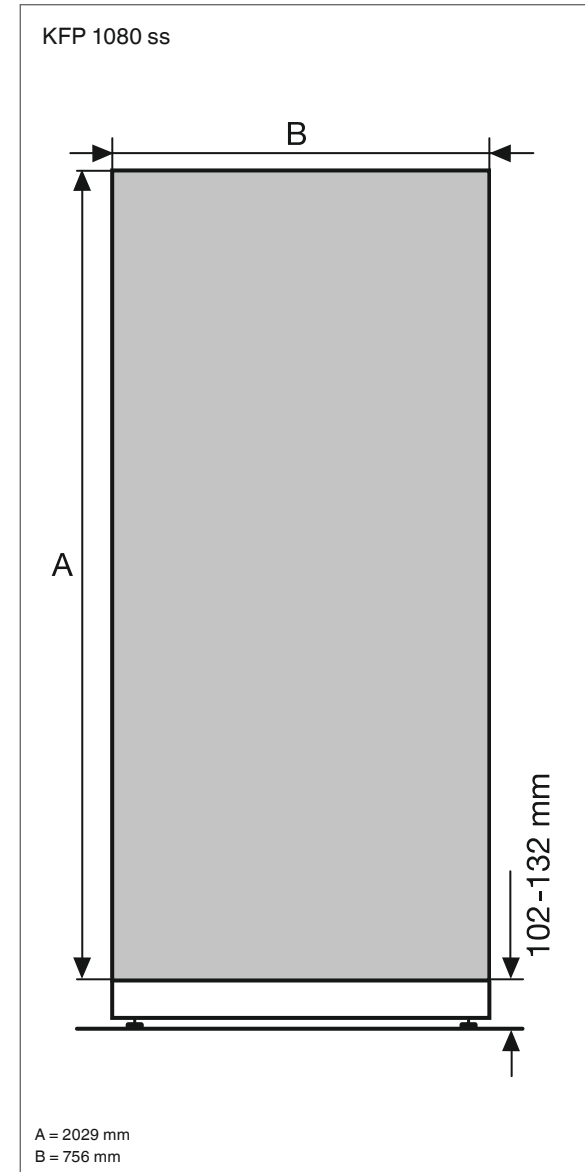
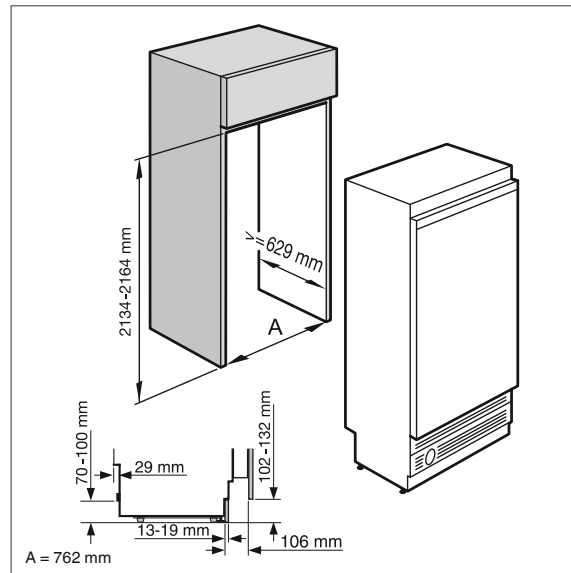
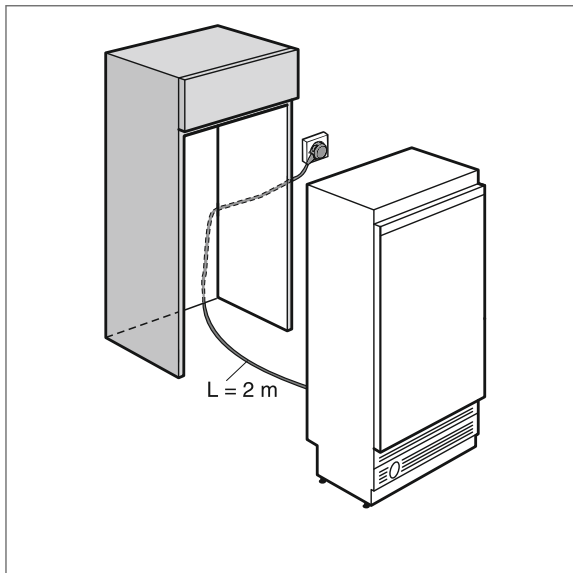
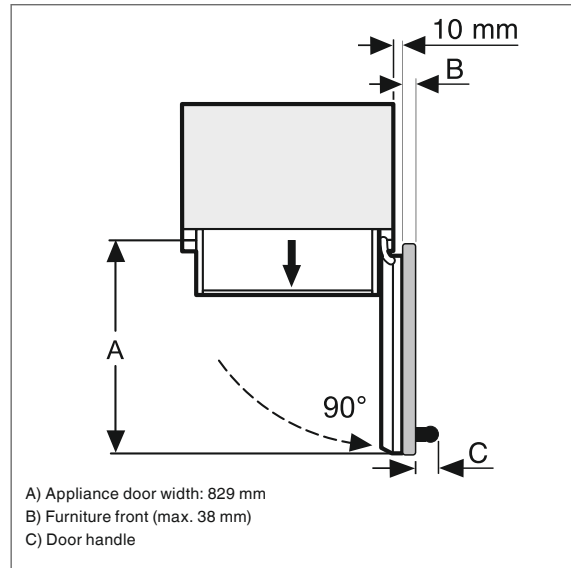
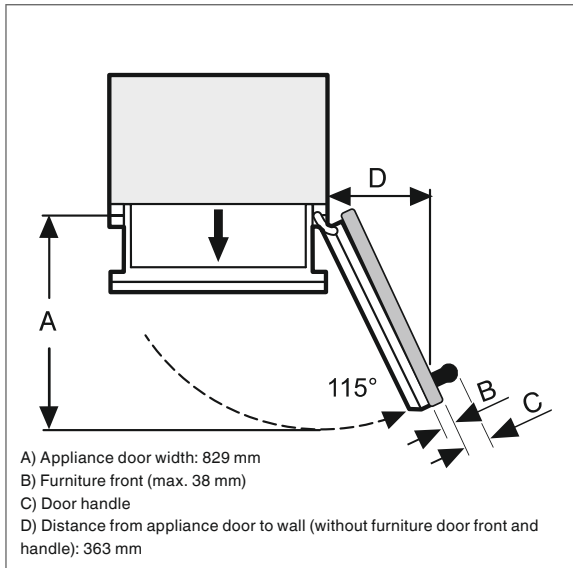

Technical data

Miele	
Model number	K 1801 Vi
Design	
White lacquered aluminium interior	●
MaxLoad door hinge 115° opening angle	Fixed
Door hinging right/left	●/-
Door hinging convertible	●
Controls	TouchControl
Electronic controls/digital temperature display	●/●
Temperature range	2-8°C
SuperCool function	●
Visual/acoustic alarm	●/●
Refrigerator section	
Automatic defrosting/Dynamic cooling	●/●
BrilliantLight illumination	●
Full access MasterFresh/Deli drawers	2/1
Tempered glass shelves with aluminium trim: fixed/adjustable	1/3
Drop&Lock door shelves/dairy compartment	3/1
Total usable capacity	549
Refrigerator zone	376
MasterFresh zone	173
Optional accessories	
Side-by-side fitting kit	KSK 1002
Stainless steel front panel	KFP 1080 ss
Plinth grille in stainless steel effect	KG 1380 ss
Dimensions and weight	
Niche height in mm	2134
Niche width in mm	762
Niche depth in mm	629
Appliance H x W x D in mm (excl. door front thickness)	2127 x 750 x 610
Appliance weight net/gross (kg)	189/211
Upper door weight (kg)/max. thickness (mm)	50/19
Lower door weight (kg)/max. thickness (mm)	-
Load bearing capacity of the floor (kg)	452
Technical specification	
Energy efficiency star rating	2
Energy consumption per year	250 kWh
Voltage	220-240 V
Connected load	672 watts
Noise levels in dB(A)re1pW	40
Climate class/Suitable for ambient temperature range	SN-T/10°C-43°C

Design

- Fully integrated refrigerator
- Door hinged right, convertible
- White lacquered aluminium interior
- Side-by-side combination enabled (optional accessory required KSK 1002)

Controls

- TouchControl electronics
- Precise electronic temperature control

Refrigerator section

- BrilliantLight illumination
- Dynamic cooling
- SuperCool
- Drop & Lock shelving with slide rail system allows for height adjustment in 1.5 cm increments.
- 3 fully adjustable tempered glass shelves with aluminium trim
- 1 fixed tempered glass shelf with aluminium trim
- 1 full access deli drawer
- 2 full access MasterFresh drawers

Inner door section

- Drop & Lock shelving with slide rail system allows for height adjustment in 1.5 cm increments.
- Butter and Cheese compartment
- 3 fully adjustable door shelves and racks with aluminium trim

Safety

- Visual and acoustic temperature alarm

Optional accessories

- KSK 1002 side-by-side installation kit
- KFP 1080 ss stainless steel door panel
- KG 1380 ss lower grille in stainless steel look



MasterCool freezer F 1811 Vi.



Installation diagram

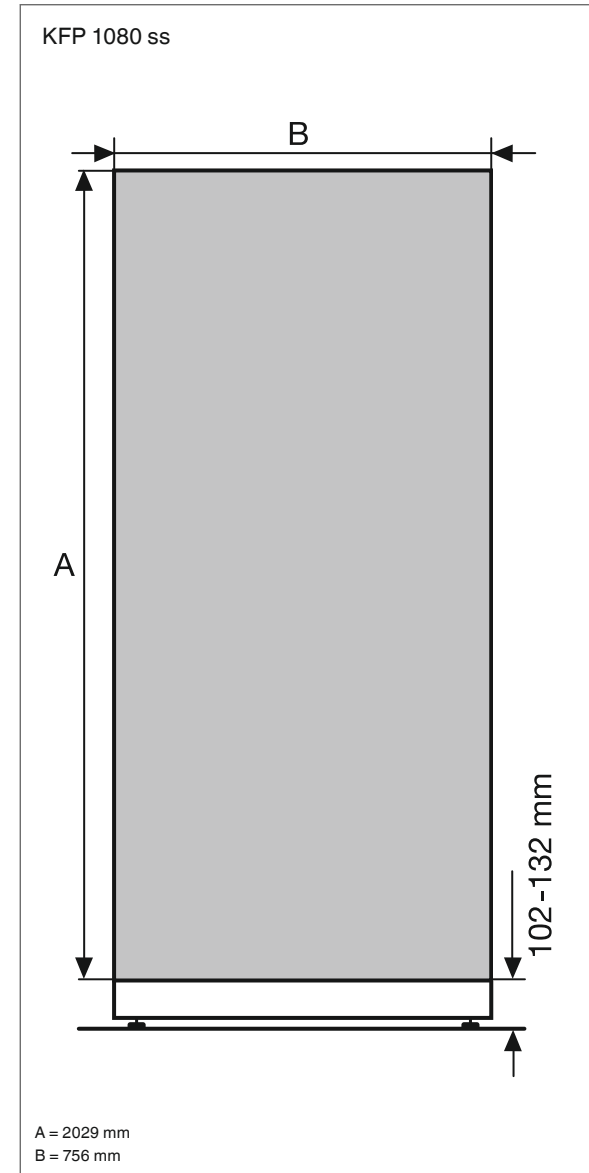
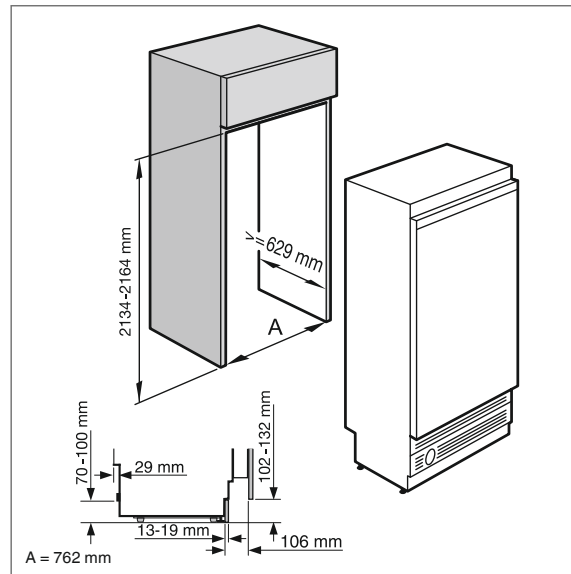
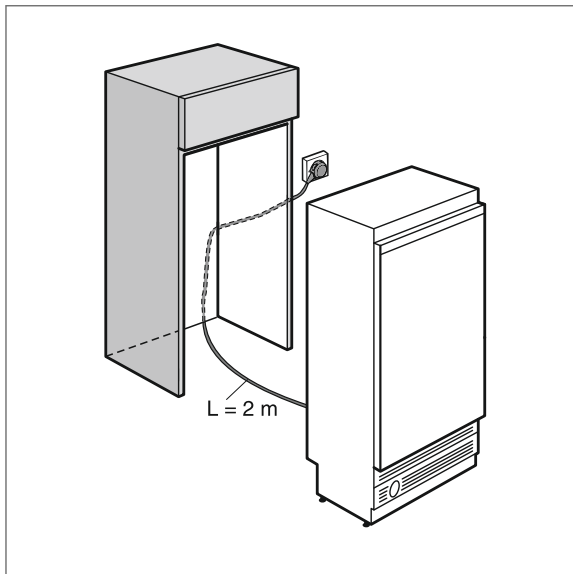
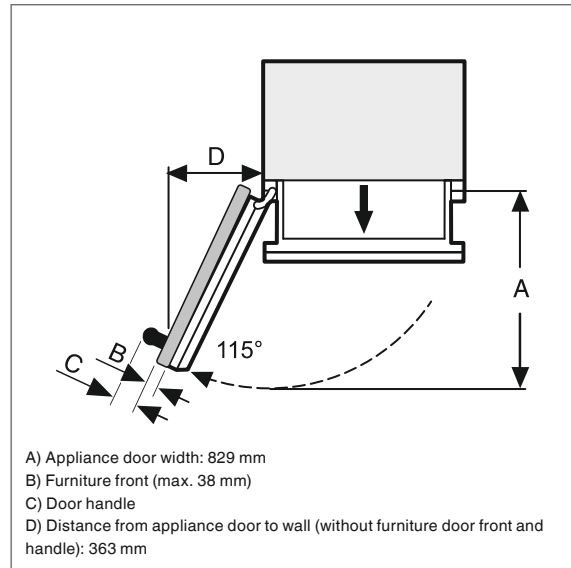
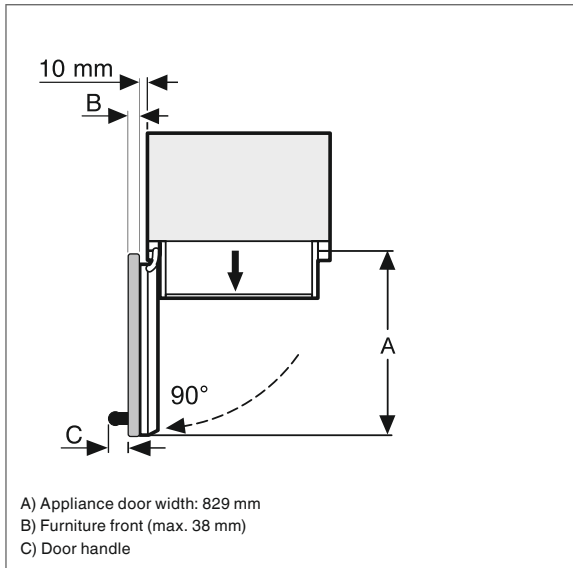

Technical data

Miele	
Model number	F 1811 Vi
Design	
White lacquered aluminium interior	●
MaxLoad door hinge 115° opening angle	Fixed
Door hinging right/left	-/●
Door hinging convertible	●
Controls	TouchControl
Electronic controls/digital temperature display	●/●
Temperature range	-14 to -24°C
SuperFreeze function	●
Visual/acoustic alarm	●/●
Frost free freezer section	
BrilliantLight illumination	●
IceMaker (requires plumbing)	Internal: 1.2kg/24 h
Full access freezer drawers	2
Tempered glass shelves with aluminium trim: fixed/adjustable	1/3
Drop&Lock door shelves	4
Total usable capacity	495
Freezer zone	495
Standard accessories	
Stainless steel water inlet hose	3 m
Water filter	KB 1000
Optional accessories	
Side-by-side fitting kit	KSK 1002
Stainless steel front panel	KFP 1080 ss
Plinth grille in stainless steel effect	KG 1380 ss
Water filter with active charcoal	KWF 1000
Dimensions and weight	
Niche height in mm	2134
Niche width in mm	762
Niche depth in mm	629
Appliance H x W x D in mm (excl. door front thickness)	2127 x 750 x 610
Appliance weight net/gross (kg)	191/213
Upper door weight (kg)/max. thickness (mm)	52/19
Lower door weight (kg)/max. thickness (mm)	-
Load bearing capacity of the floor (kg)	430
Technical specification	
Energy efficiency star rating	2
Energy consumption per year	620 kWh
Voltage	220-240 V
Connected load	587 watts
Storage time in the event of a fault/Max. freezing capacity	20 h/18.5 kg
Noise levels in dB(A)re1pW	42
Climate class/Suitable for ambient temperature range	SN-T/10°C-43°C

Design

- Fully integrated freezer
- Door hinged left, convertible
- White lacquered aluminium interior
- Side-by-side combination enabled (optional accessory required KSK 1002)

Controls

- TouchControl electronics
- Precise electronic temperature control

Freezer section

- BrilliantLight illumination
- NoFrost
- SuperFreeze function
- Drop & Lock system
- 3 fully adjustable metal shelves
- 1 metal grille with aluminium frame
- 2 full access telescopic metal baskets with aluminium frame
- Internal automatic ice-maker
- Ice making capacity: 1.2 kg/24 hours

Inner door section

- Drop & Lock shelving with slide rail system allows for individual height adjustment of 4 metal grille baskets.

Standard accessories

- KB 1000 Bypass screen filter
- 3 m stainless steel braided water inlet hose

Safety

- Visual and acoustic temperature alarm

Optional accessories

- KSK 1002 side-by-side installation kit
- KFP 1080 ss stainless steel door panel
- KG 1380 ss lower grille in stainless steel look
- KWF 1000 water filter



MasterCool freezer F 1471 Vi.



Installation diagram

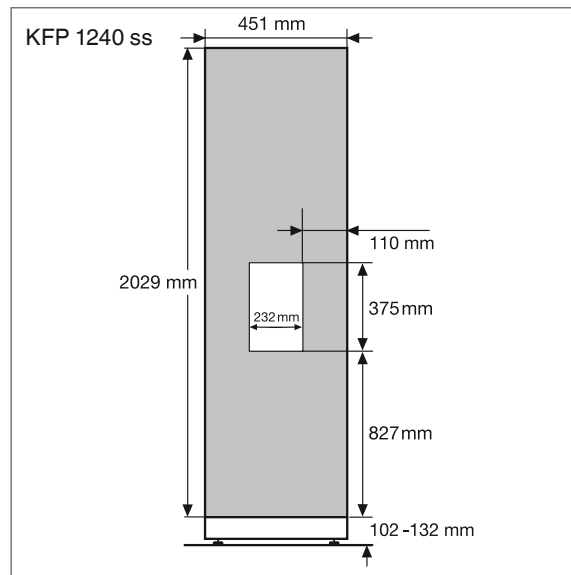
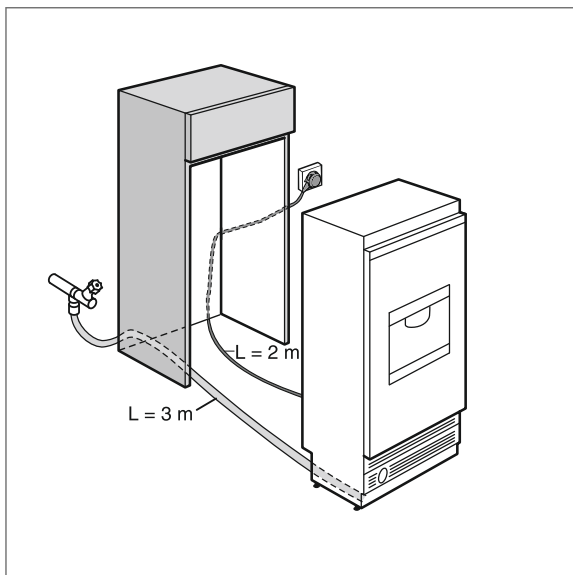
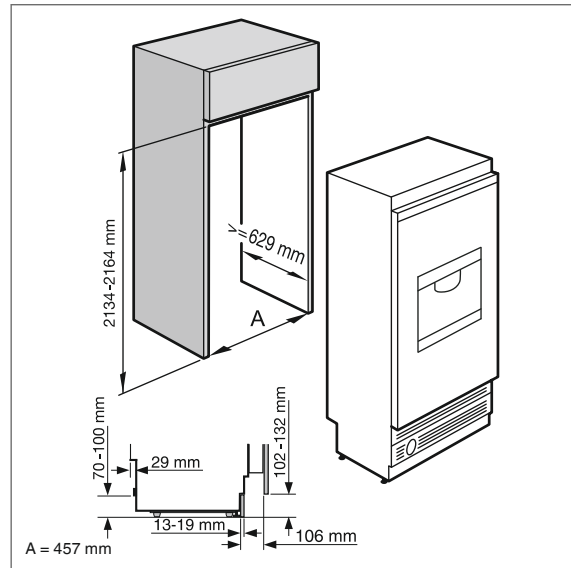
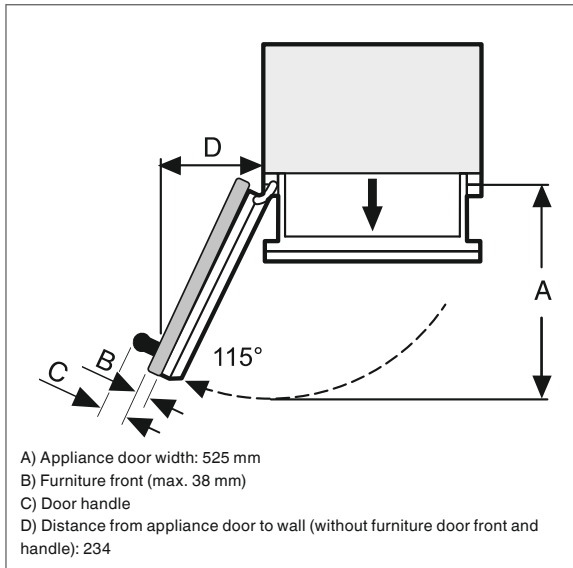

Technical data

Miele	
Model number	F 1471 Vi
Design	
White lacquered aluminium interior	●
MaxLoad door hinge 115° opening angle	Fixed
Door hinging right/left	-/●
Door hinging convertible	●
Controls	TouchControl
Electronic controls/digital temperature display	●/●
Temperature range	-14 to -24°C
SuperFreeze function	●
Visual/acoustic alarm	●/●
Frost free freezer section	
BrilliantLight illumination	●
IceMaker (requires plumbing)	In door: 1.5kg/24 h
Full access freezer drawers	2
Tempered glass shelves with aluminium trim: fixed/adjustable	1/1
Drop&Lock door shelves	1
Total usable capacity	495
Freezer zone	495
Standard accessories	
Stainless steel water inlet hose	3 m
Water filter	KB 1000
Optional accessories	
Side-by-side fitting kit	KSK 1002
Stainless steel front panel	KFP 1080 ss
Plinth grille in stainless steel effect	KG 1380 ss
Water filter with active charcoal	KWF 1000
Dimensions and weight	
Niche height in mm	2134
Niche width in mm	457
Niche depth in mm	629
Appliance H x W x D in mm (excl. door front thickness)	2127 x 445 x 610
Appliance weight net/gross (kg)	139/149
Upper door weight (kg)/max. thickness (mm)	65/19
Lower door weight (kg)/max. thickness (mm)	-
Load bearing capacity of the floor (kg)	228
Technical specification	
Energy efficiency star rating	1,5
Energy consumption per year	485 kWh
Voltage	220-240 V
Connected load	850 watts
Storage time in the event of a fault/Max. freezing capacity	13 h/14 kg
Noise levels in dB(A)re1pW	41
Climate class/Suitable for ambient temperature range	SN-T/10°C-43°C

Design

- Fully integrated freezer
- Door hinged left
- White lacquered aluminium interior
- Side-by-side combination enabled (optional accessory required KSK 1002)

Controls

- TouchControl electronics
- Precise electronic temperature control

Freezer section

- BrilliantLight illumination
- NoFrost
- SuperFreeze function
- Drop & Lock system
- 1 adjustable metal grille
- 2 full access telescopic metal baskets with aluminium frame
- Ice and water dispenser through the door
- Internal automatic ice-maker
- Ice making production: 1.5 kg/24 hours

Inner door section

- Drop & Lock system
- Metal grille basket with aluminium surround

Standard accessories

- KB 1000 Bypass screen filter
- 3 m stainless steel braided water inlet hose

Safety

- Visual and acoustic temperature alarm

Optional accessories

- KSK 1002 side-by-side installation kit
- KFP 1240 ss stainless steel door panel with provision for ice and water dispenser
- KG 1140 ss lower grille in stainless steel look
- KWF 1000 water filter



MasterCool fridge/freezer combination KF 1911 Vi



Installation diagram

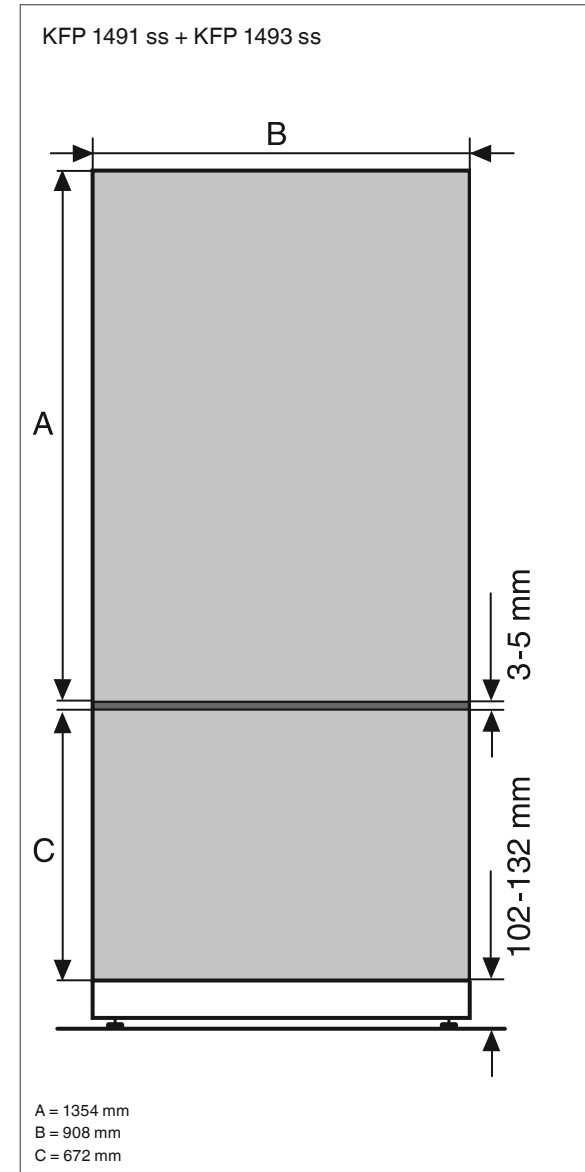
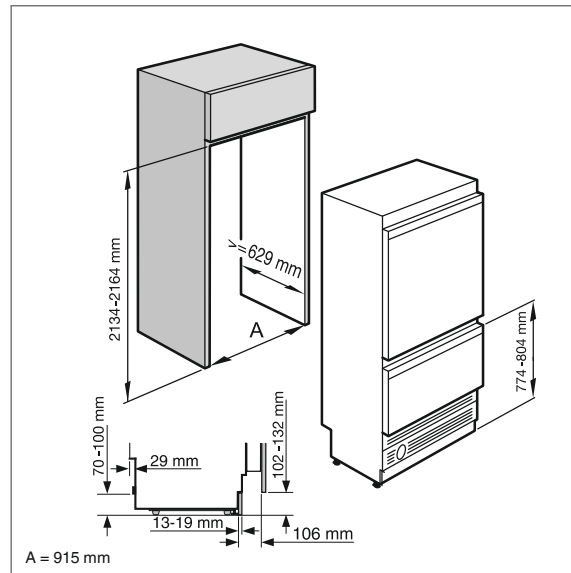
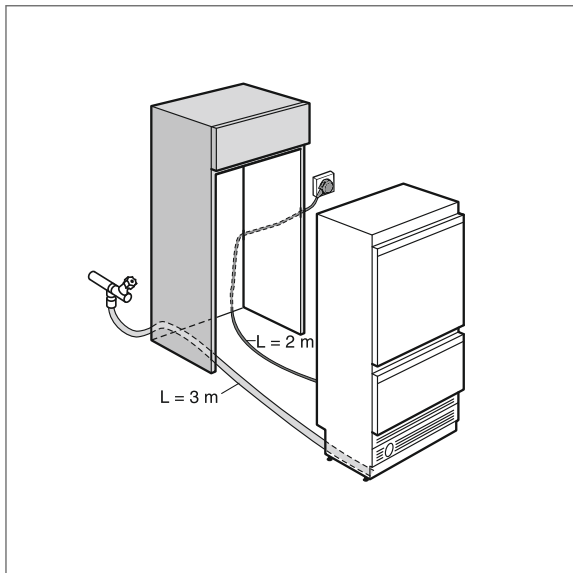
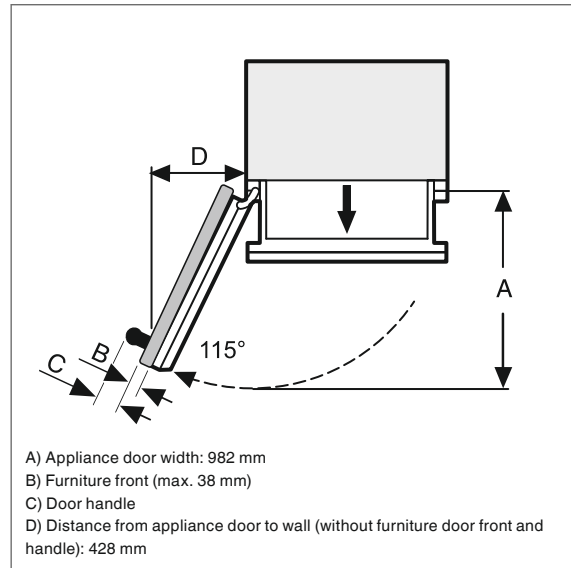
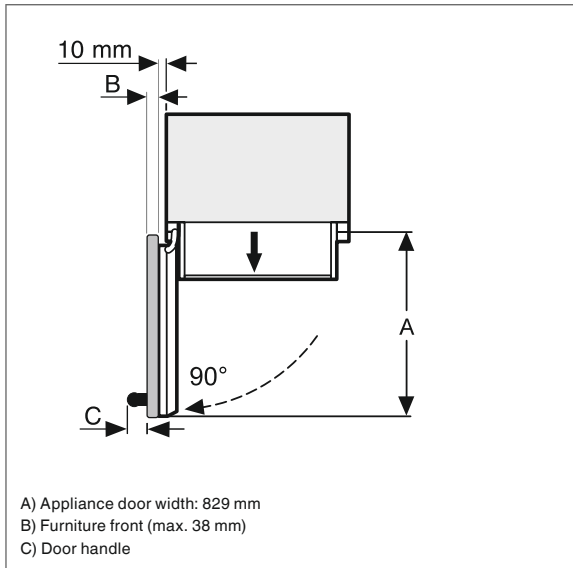

Technical data

Miele	
Model number	KF 1911 Vi
Design	
White lacquered aluminium interior	●
MaxLoad door hinge 115° opening angle	Fixed
Door hinging right/left	●/–
Door hinging convertible	●
Controls	TouchControl
Electronic controls/digital temperature display	●/●
Temperature range Fridge/Freezer	2–8°C/–14 to –24°C
SuperCool/SuperFreeze function	●/●
Visual/acoustic alarm	●/●
Refrigerator section	
Automatic defrosting/Dynamic cooling	●/●
BrilliantLight illumination	●
Full access MasterFresh drawers	1 (split storage zones)
Floating deli drawer	●
Tempered glass shelves with aluminium trim: fixed/adjustable	1/3
Drop&Lock door shelves/dairy compartment	2/1
Frost free freezer section	
BrilliantLight illumination	●
IceMaker (requires plumbing)	Internal: 1.1 kg/24 h
Full access freezer drawers	1 large/1 small
Total usable capacity	642
Refrigerator zone	362
MasterFresh zone	104
Freezer section	176
Standard accessories	
Stainless steel water inlet hose	3 m
Water filter	KB 1000
Optional accessories	
Side-by-side fitting kit	KSK 1002
Stainless steel front panel	KFP 1491 ss/KFP 1493 ss
Plinth grille in stainless steel effect	KG 1490 ss
Dimensions and weight	
Niche height in mm	2134
Niche width in mm	915
Niche depth in mm	629
Appliance H x W x D in mm (excl. door front thickness)	2127 x 902 x 610
Appliance weight net/gross (kg)	225/249
Upper door weight (kg)/max. thickness (mm)	38/19
Lower door weight (kg)/max. thickness (mm)	14/19
Load bearing capacity of the floor (kg)	537
Technical specification	
Energy efficiency star rating	3
Energy consumption per year	530 kWh
Voltage	220–240 V
Connected load	802 watts
Noise levels in dB(A)re1pW	42
Climate class/Suitable for ambient temperature range	SN–T/10°C–43°C

Design

- Fully integrated fridge-freezer
- Door hinged left, convertible
- White lacquered aluminium interior
- Side-by-side combination enabled (optional accessory required KSK 1002)

Controls

- TouchControl electronics
- Precise electronic temperature control

Refrigerator zone

- BrilliantLight illumination
- Dynamic cooling, SuperCool function
- Drop & Lock rail system
- Tempered glass shelves with aluminium trim
- 3 fully adjustable shelves
- 1 fixed shelf, 1 Deli drawer
- 1 MasterFresh drawer on fully telescopic rails with 2 individually adjustable sections

Freezer zone

- NoFrost
- 1 large pull out metal grille basket on fully extendable telescopic rails
- Small internal metal grille basket with aluminium frame on fully extendable telescopic rails
- Automatic internal ice-maker
- Ice making production: 1.1 kg/24 hours

Inner door section

- Drop & Lock shelving with slide rail system allows for height adjustment in 1.5 cm increments.
- Butter and cheese compartment
- 2 adjustable aluminium frames

Standard accessories

- KB 1000 Bypass screen filter
- 3 m stainless steel metal braided hose

Safety

- Visual and acoustic temperature alarm

Optional accessories

- KSK 1002 side-by-side installation kit
- KFP 1491 ss stainless steel fridge door panel
KFP1493 ss stainless steel freezer door panel
- KG 1490 ss lower grille in stainless steel look
- KWF 1000 water filter



MasterCool wine conditioning unit KWT 1601 Vi



Installation diagram

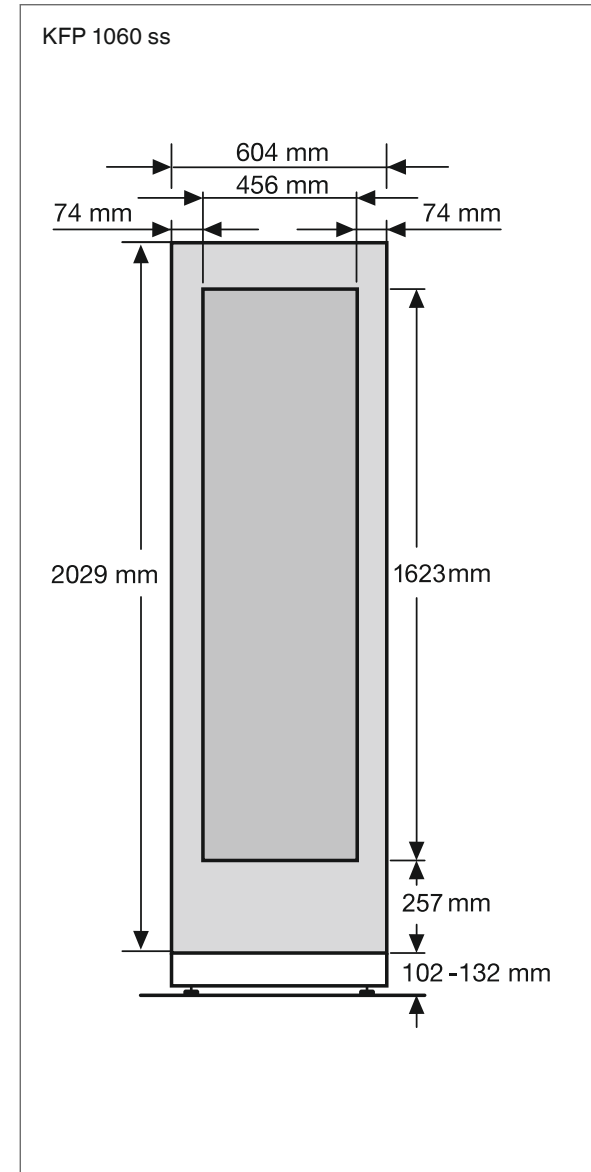
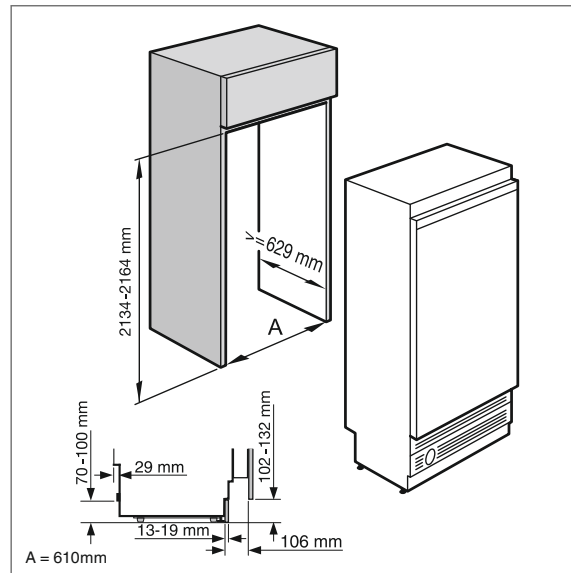
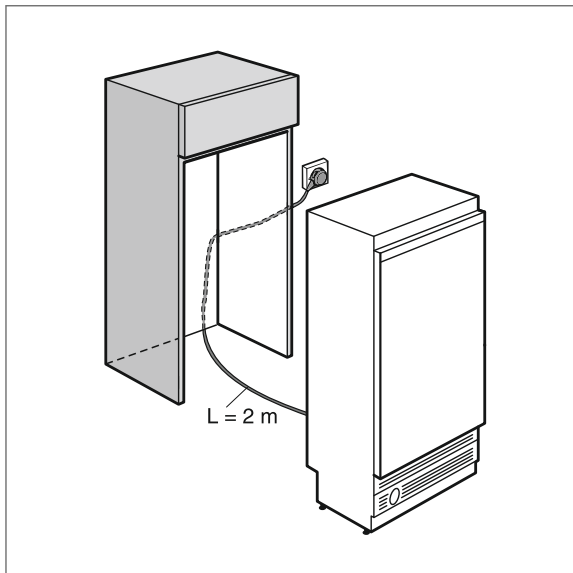
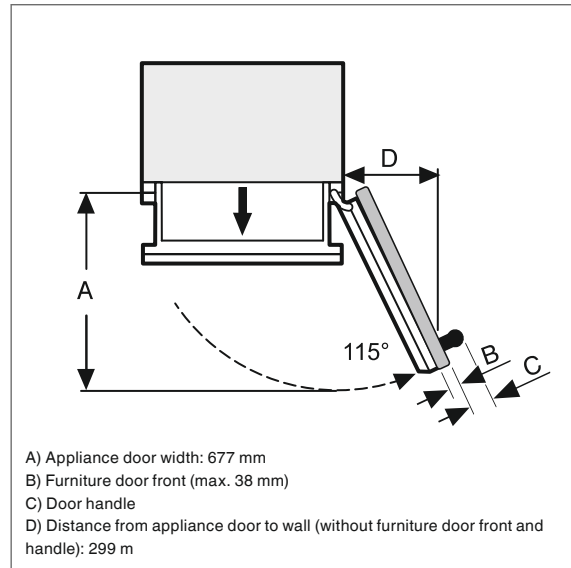
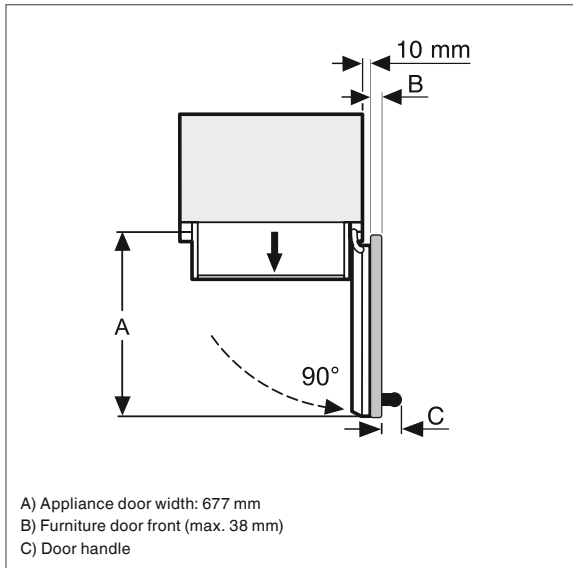

Technical data

Miele	
Model number	KWT 1601 Vi
Design	
Triple glazed door with UV filter	●
MaxLoad door hinge 115° opening angle	Fixed
Door hinging right/left	●/–
Door hinging convertible	●
Controls	TouchControl
Electronic controls/digital temperature display for each zone	●/●
Preset temperatures/Adjustable range	●/3–18°C
Adjustable humidity levels	●
Visual/acoustic alarm	●/●
Wine storage zones	
Dynamic cooling	●
BrilliantLight illumination/LED display lighting	●/●
No. of independently controlled zones	3
Wooden shelves:Fixed/FullAccess telescopic	2/12
Shelf labels/bottle presenter	●/●
Vibration free storage/Active charcoal filters	●/●
Total usable capacity	
Max. 0.75 litre Bordeaux bottles	102
Optional accessories	
Side-by-side fitting kit	KSK 1002
Stainless steel front panel	KFP 1060 ss
Plinth grille in stainless steel effect	KG 1560 ss
Dimensions and weight	
Niche height in mm	2134
Niche width in mm	610
Niche depth in mm	629
Appliance H x W x D in mm (excl. door front thickness)	2127 x 597 x 610
Appliance weight net/gross (kg)	153/172
Upper door weight (kg)/max. thickness (mm)	62/19
Lower door weight (kg)/max. thickness (mm)	–
Load bearing capacity of the floor (kg)	319
Technical specification	
Voltage	220–240 V
Connected load	340 watts
Noise levels in dB(A)re1pW	42
Climate class/Suitable for ambient temperature range	SN–T/10°C–43°C

Design

- Fully integrated wine conditioner
- Right hinged, convertible
- Triple door glazing with UV filter
- Lacquered aluminium interior
- Side-by-side combination enabled
(optional accessory required KSK 1002)

Controls

- TouchControl electronics
- Precise electronic temperature control

3 Temperature zones

- BrilliantLight illumination
- 3 individually adjustable temperature zones
- Temperature range 3–18° C
- 14 acacia wood shelves
- Full access telescopic rails
- Vibration free storage
- LED presentation lighting
- ActiveCharcoal filter

Safety

- Visual and acoustic temperature alarm

Optional accessories

- KSK 1002 side-by-side installation kit
- KFP 1060 ss stainless steel panel with provision for glass door
- KG 1560 ss lower grille in stainless steel look



Accessories

Door panels

Optional stainless steel door panels are available for all Miele MasterCool appliances at an additional cost. These door panels have a thickness of 19 mm and have no pre-drilled holes for handles. To keep the same design elements with other Miele appliances, we recommend the DS 5003 handles which match the H 5000 series ovens.



KB 1000 Bypass screen filter and KWF 1000 water filter

Miele MasterCool units with integrated ice maker come supplied as standard with a Bypass filter. This filter filters out particulate matter in the water supply. The KWF 1000 water filter will also remove chlorine.





KSK 1002 side-by-side installation kit

Side-by-side installation kit including side wall heating is an essential accessory for combining appliances into one niche. For all 4 appliance types (K, F, KF, KWT).

Upper ventilation grille

Door hinging can be changed over on the 60 cm, 75 cm and 90 cm units. This can be done at point of installation. Please note that an optional upper grille in white with the correct hinge positioning is needed to complete the hinge changeover.



Lower ventilation grille in stainless steel look

Optional grille to match with optional stainless steel door panels.

